

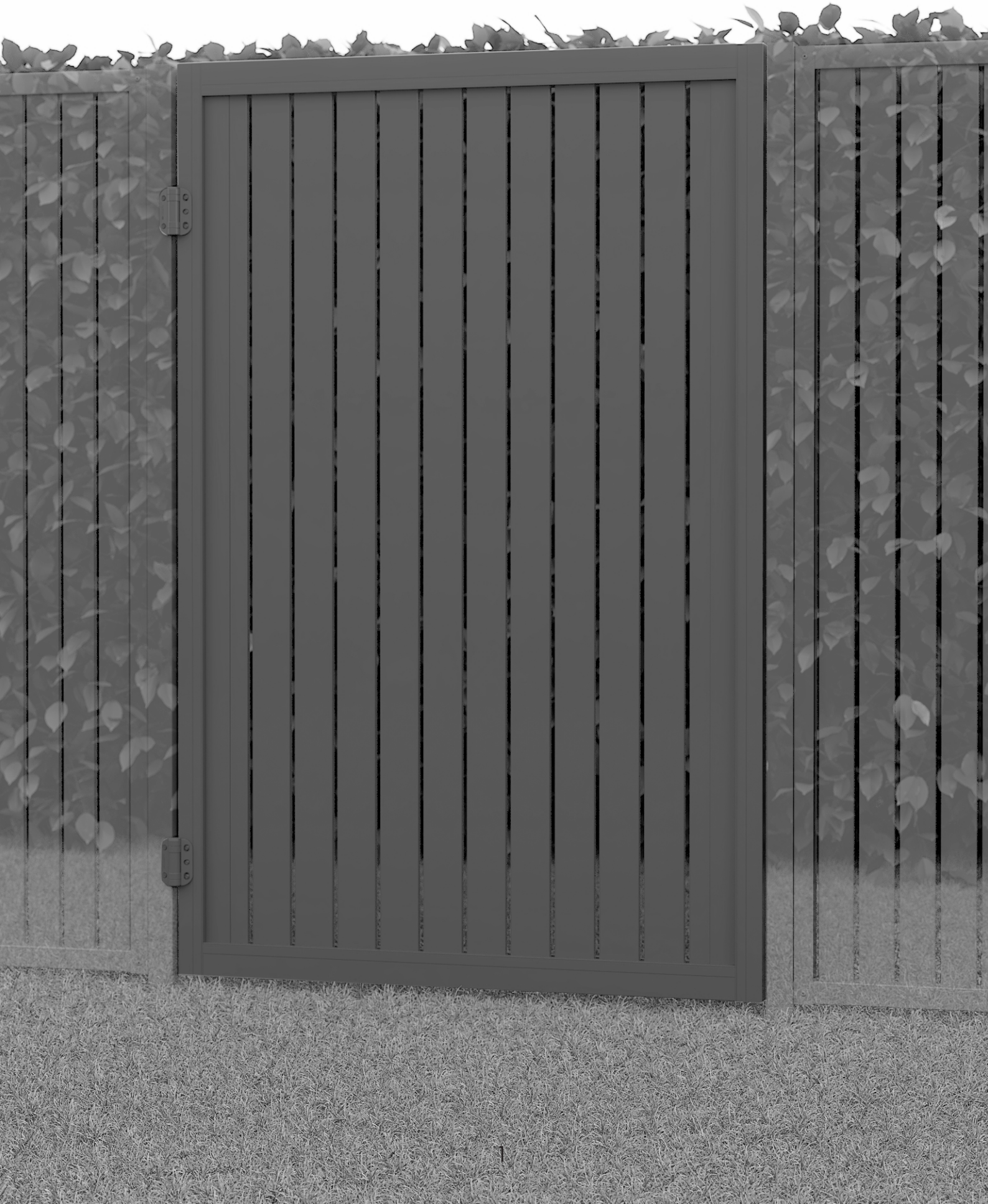

**QUICKSCREEN GATE**  
**VERTICAL SLAT SCREENING**  
**HINGED PEDESTRIAN GATE**

**FABRICATION**  
**OVERVIEW**





65mm Slat or  
90mm Slat



Gate Side Frame

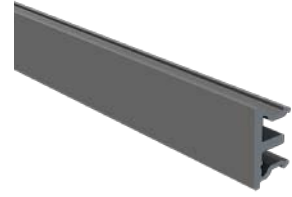

Gate Screw Cover



65mm Top/  
Bottom Rail



Gate Infill



Gate Channel Infill



Joiner Blocks and  
Screws for Top/Bottom  
Rails



Panhead Screws



Self-drilling  
Wafer Screws



Slat Spacers



Gate Top Cap

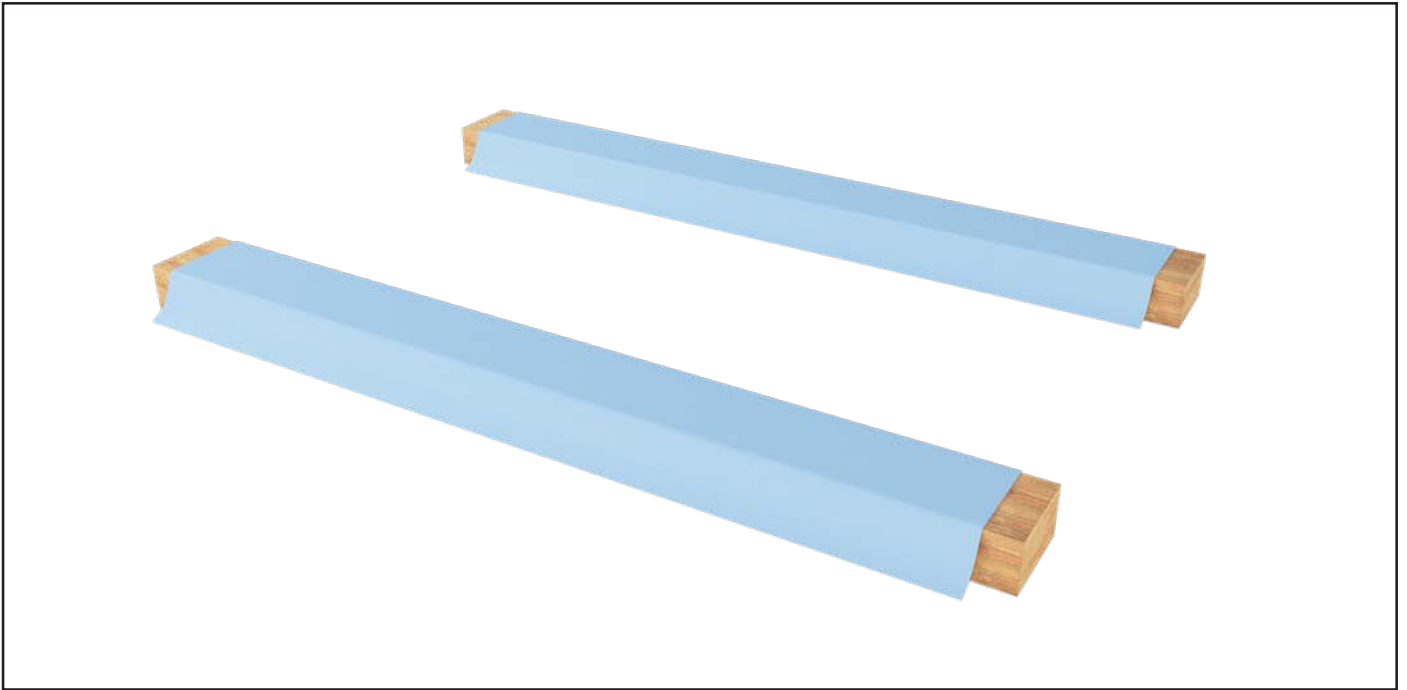

1 Set up the gate fabrication area on a flat, protected surface or padded bearers



2 Attach the Joiner Blocks to both ends of the Top Rail, and one end of the Bottom Rail, with two screws per Joiner block, using a Phillips head #3 driver bit on a low-torque/low-speed cordless drill setting.

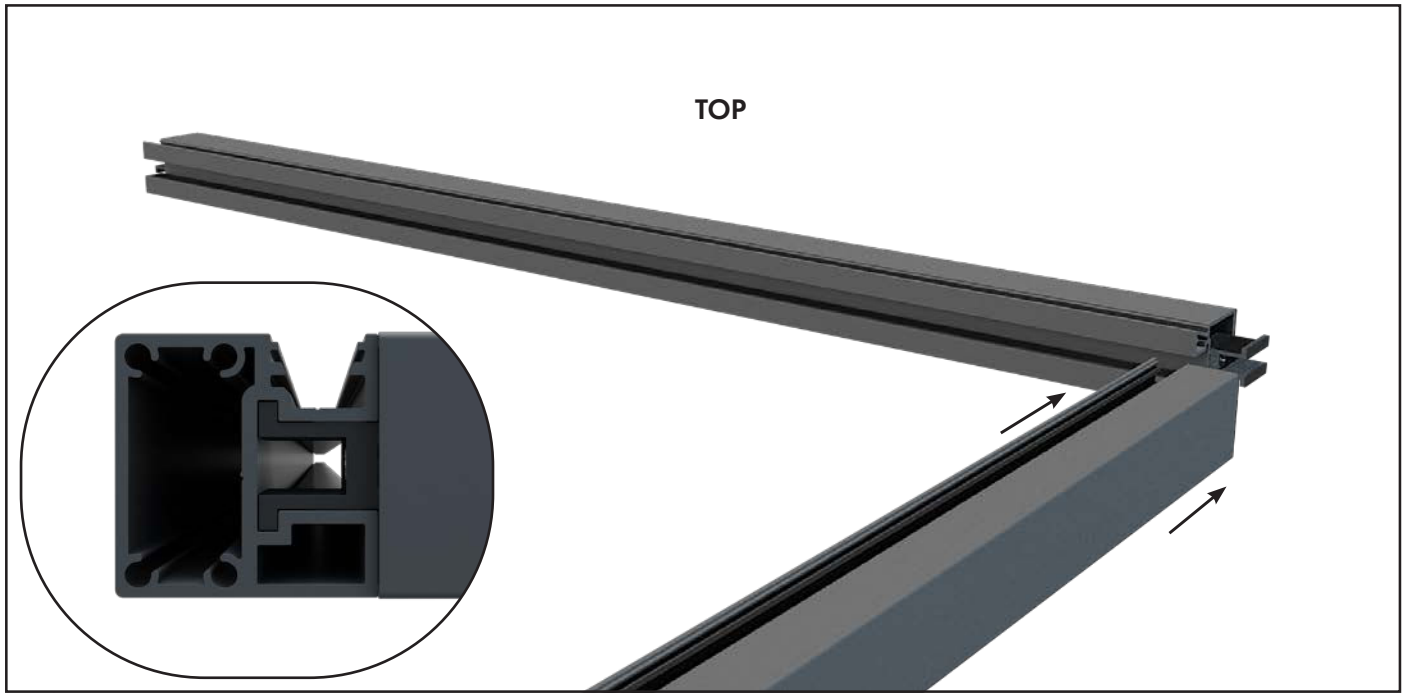

3 Slide one Gate Side Frame onto the Top Rail.

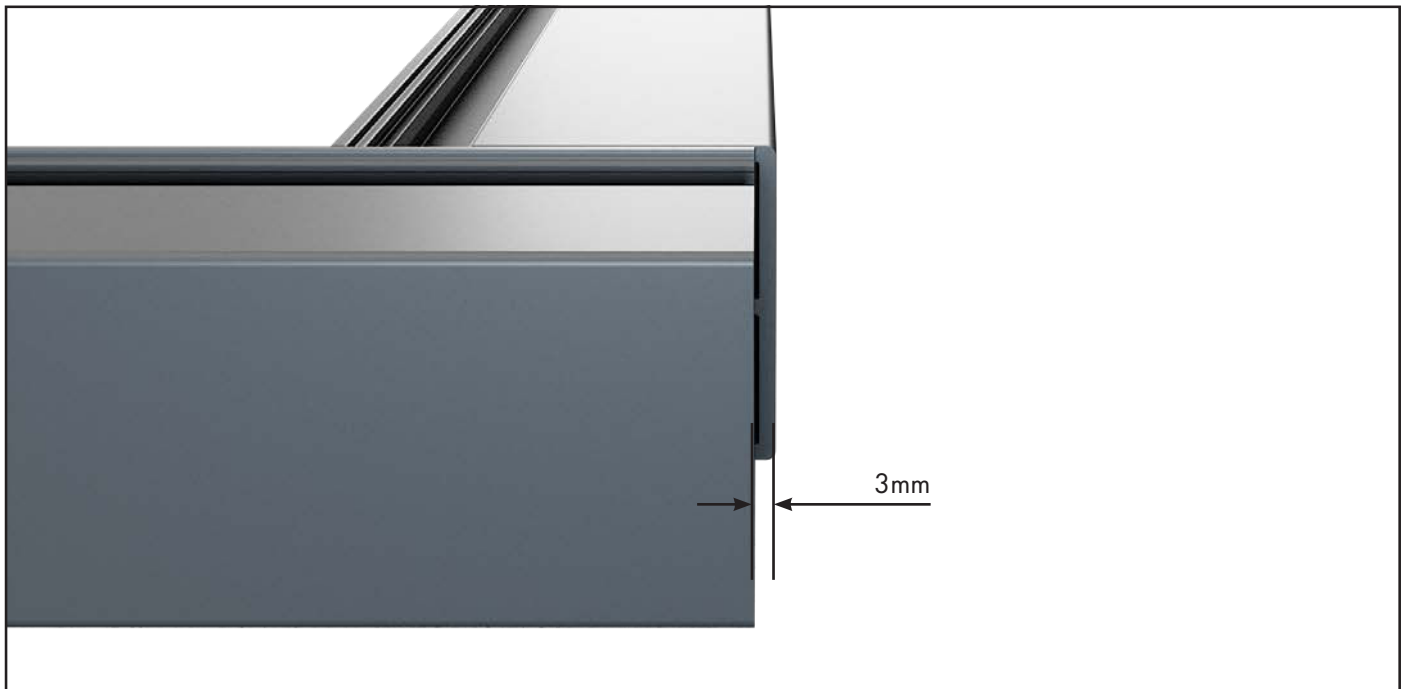

4 Leave a 3mm gap between the top of the Gate Top Rail and Gate Side Frame to allow for the top cap to finish flush with the Gate Top Rail.

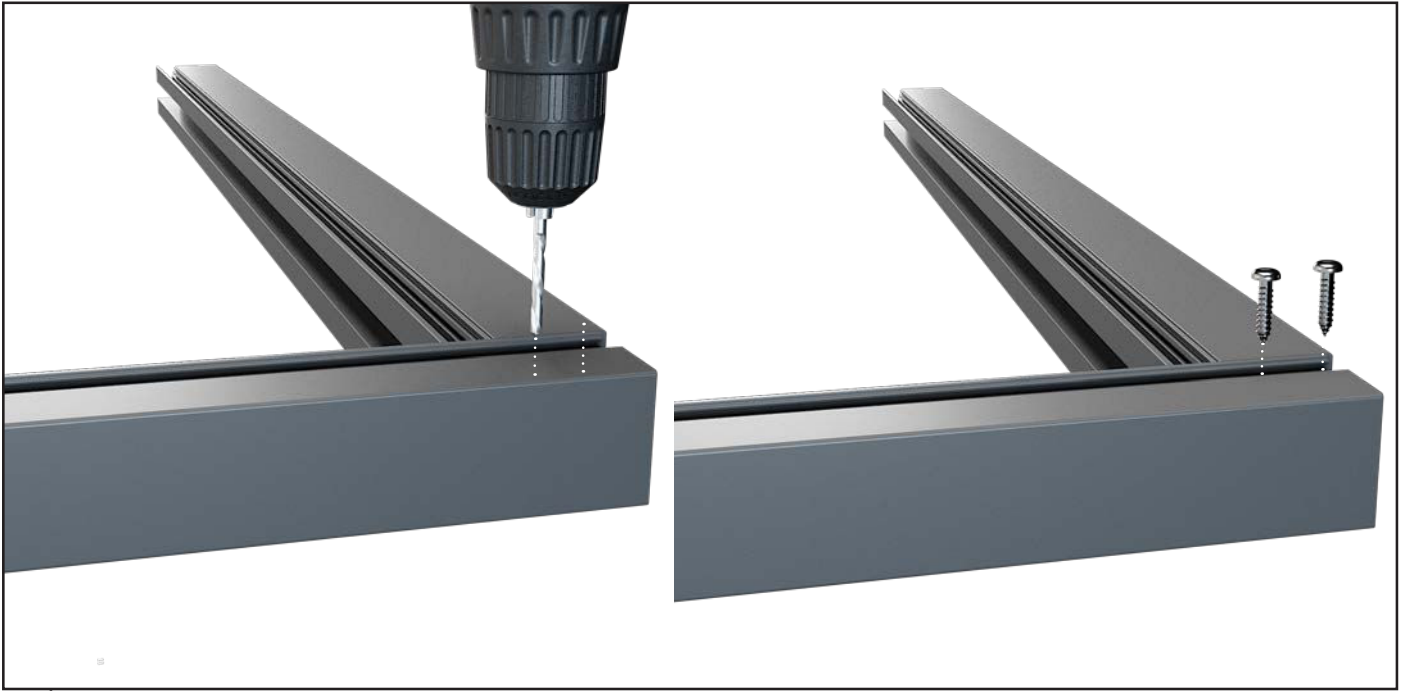

- 5 Pre-drill two 5mm holes through the Gate Side Frame screw channel and Joiner Block.  
Affix two 12G x 25mm long panhead screws per Joiner Block.

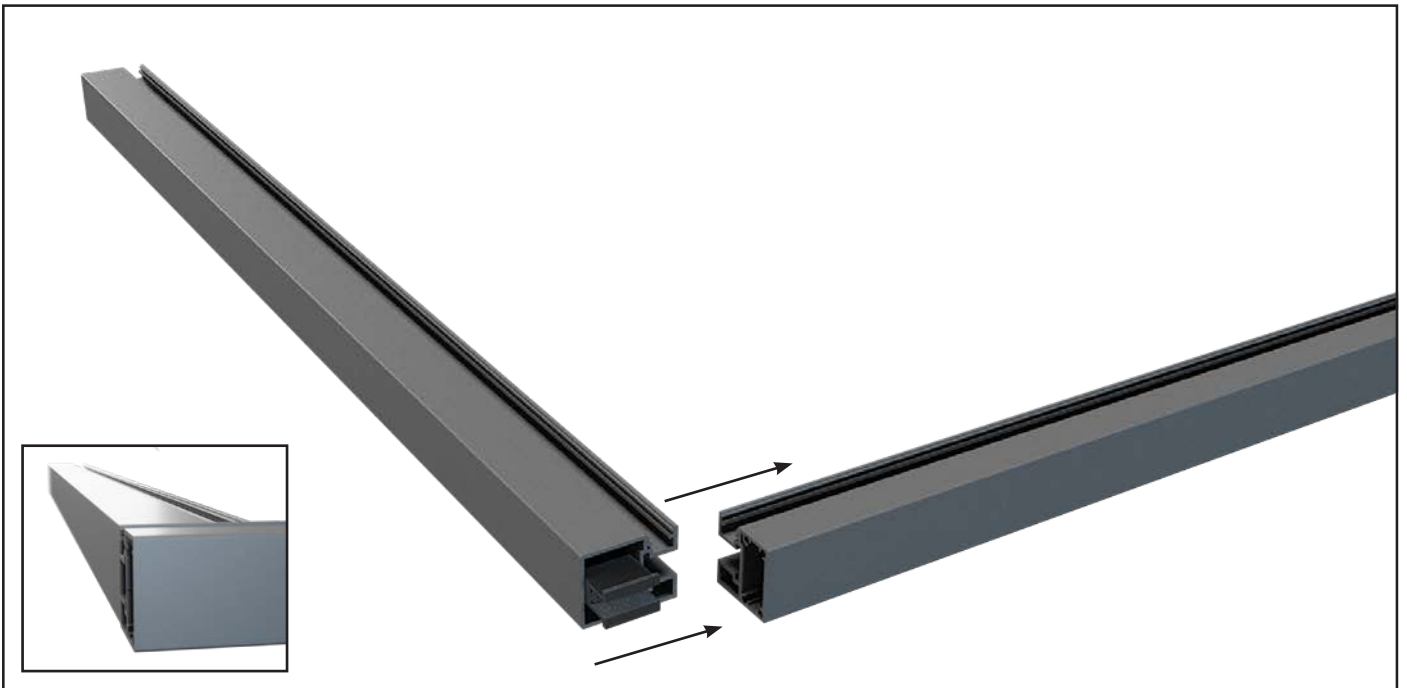

- 6 Slide the Bottom Rail with the single Joiner Block onto the Gate Side Frame, ensuring the Bottom Rail is flush with the bottom on the Gate Side Frame.

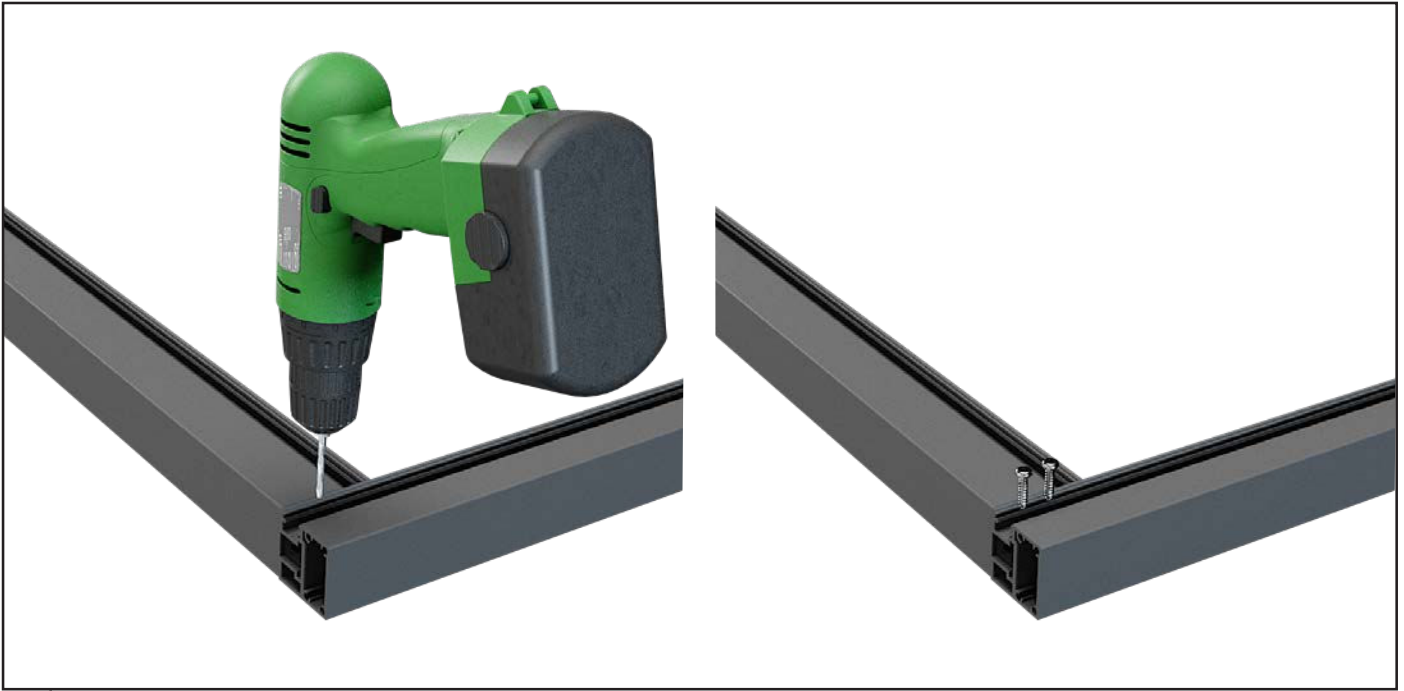

- 7 Pre-drill two 5mm holes through the Gate Side Frame screw channel and Joiner Block.  
Affix two 12G x 25mm long panhead screws per Joiner Block.

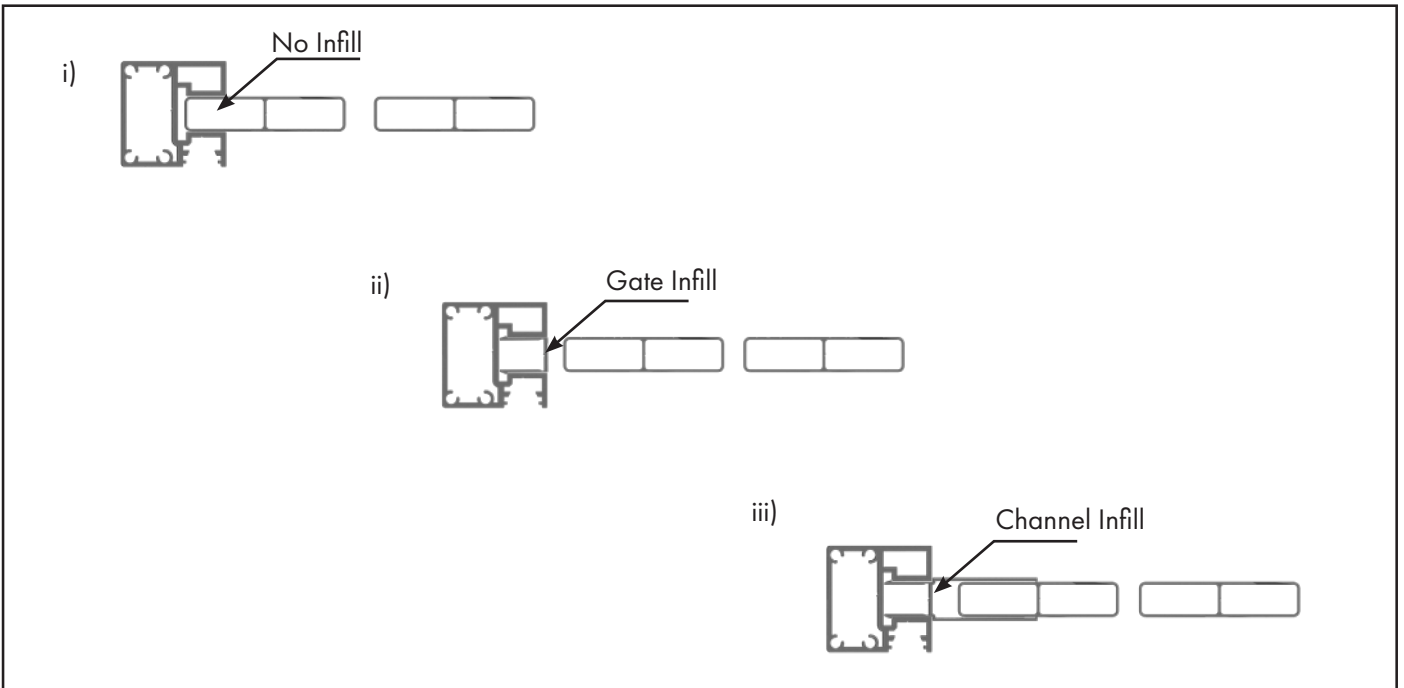

- 8 To achieve a visually even spaced slat gate, the positioning of the end slats are determined by overall gate width, slat width, and selected spacing.  
The three fabrication options are;
- i) No Infill - slats embed into the Gate Side Frame
  - ii) Gate Infill - gives a flush finish to the Gate Side Frame for the first slat gap
  - iii) Channel Infill - allows end slats to insert into the channel to hide larger end gaps

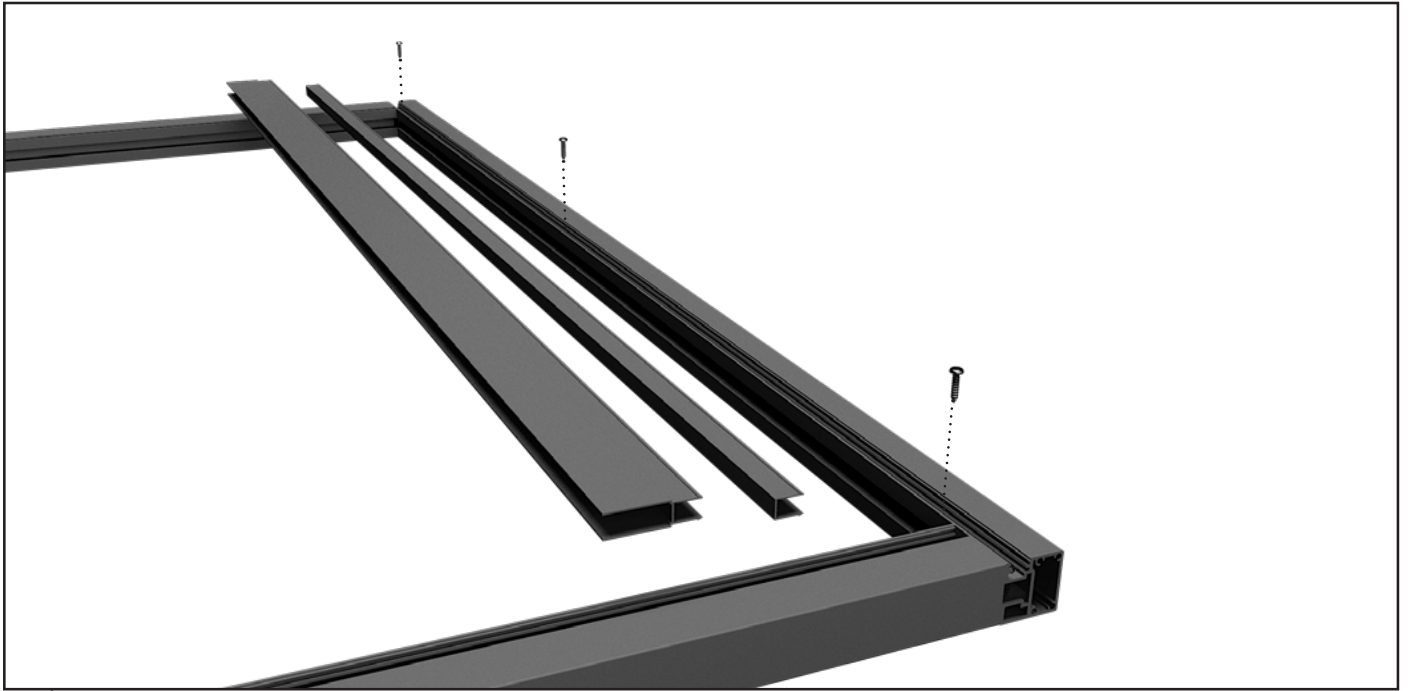

9 For option ii) Gate Infill, or option iii) Channel Infill, insert into the first Gate Side Frame and affix using the Self-drilling Wafer Screws.

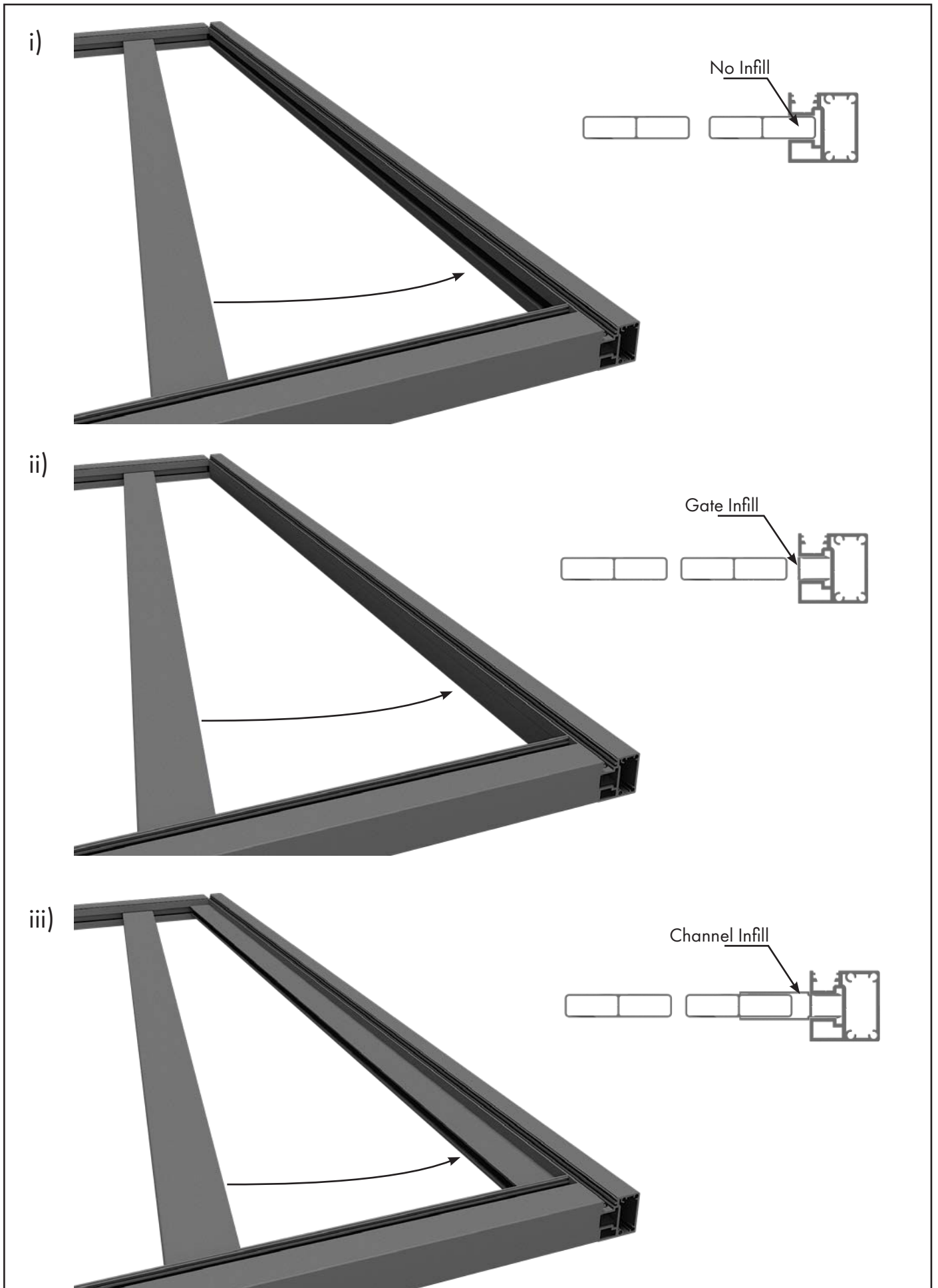

10 Insert the first vertical slat as per required option, considering slat exposure for option i) and iii), or spacing for option ii).



- 11 Once the first vertical slat is correctly positioned, secure the slat at top and bottom using the Self-drilling Wafer Screws.

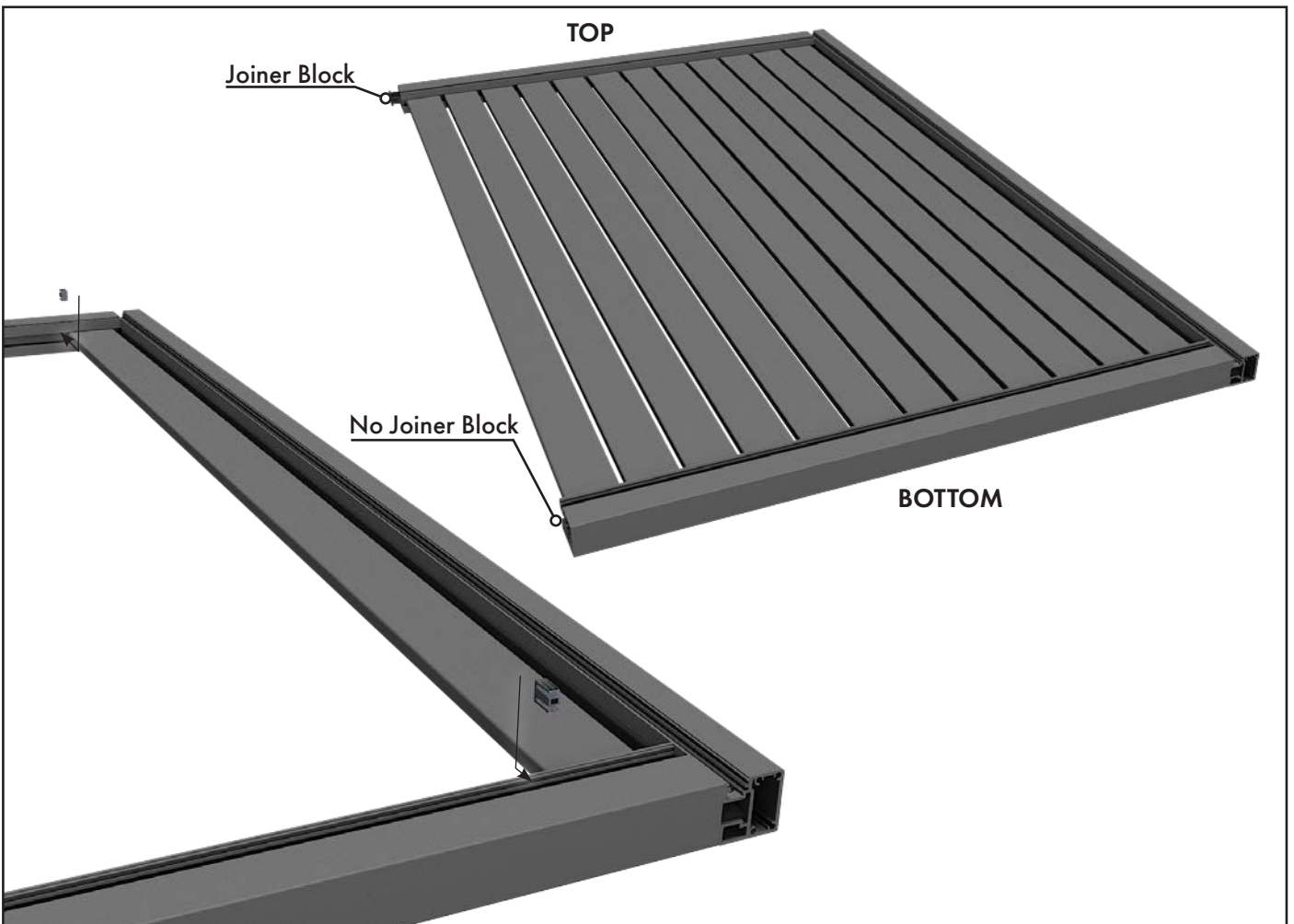

- 12 Snap the first two Spacer Blocks into position next to the first vertical slat. Position all remaining slats and spacers working along the gate.

**NOTE:** Do not screw fix slats to gate frames at this stage.

i)

If no infill being used, the final slot will overhang



ii)

If using the Gate Infill for a flush finish, slide the infill into the remaining Gate Side Frame before attaching to the gate

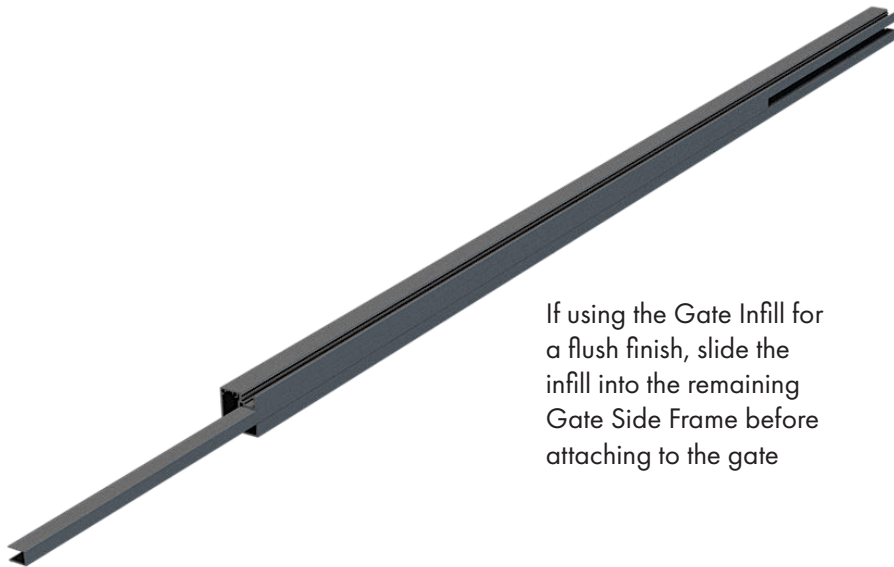

iii)

If using the Channel Infill, slide the infill over last slot and align with the edge of top/bottom rail

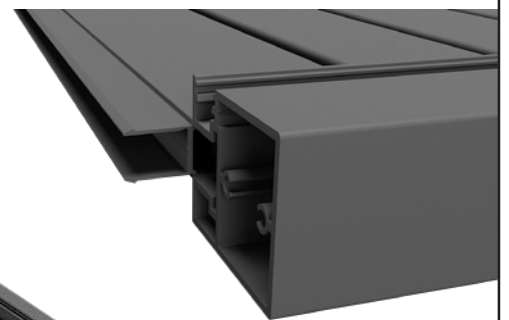

13 Position the final vertical slat and position option ii) Gate Infill, or iii) Channel Infill as required.

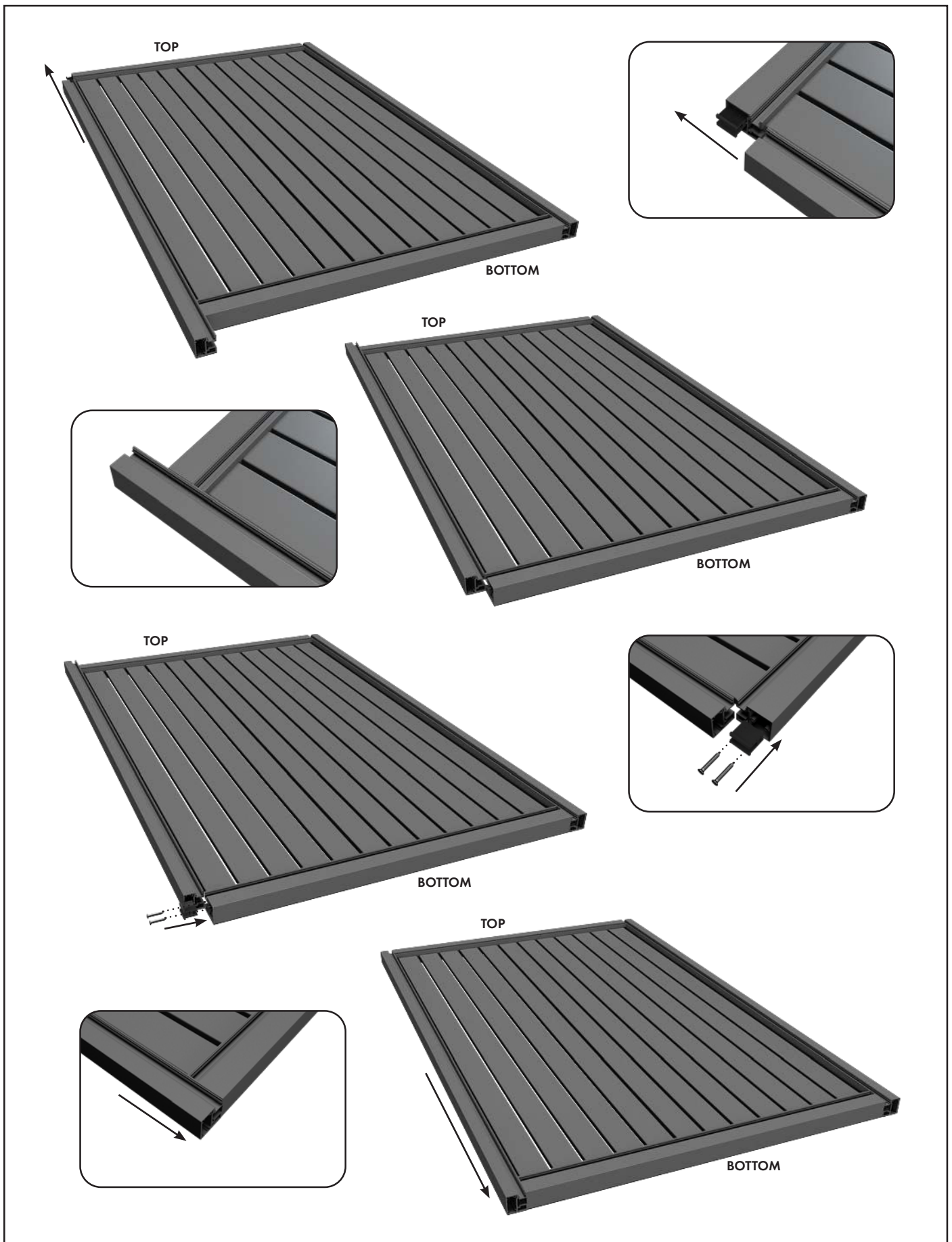

- 14 Slide the remaining Gate Side Frame onto i) the overhanging slat, or iii) the Channel Infill and onto top rail joiner block. Slide side frame slightly beyond the top rail to allow room to install Joiner Block to the bottom rail. Once block installed, slide side frame back down to connect side frame to bottom rail. The Gate Side Frame should align flush with the bottom gate rail, leaving a 3mm gap at the top rail to allow for a Top Cap.

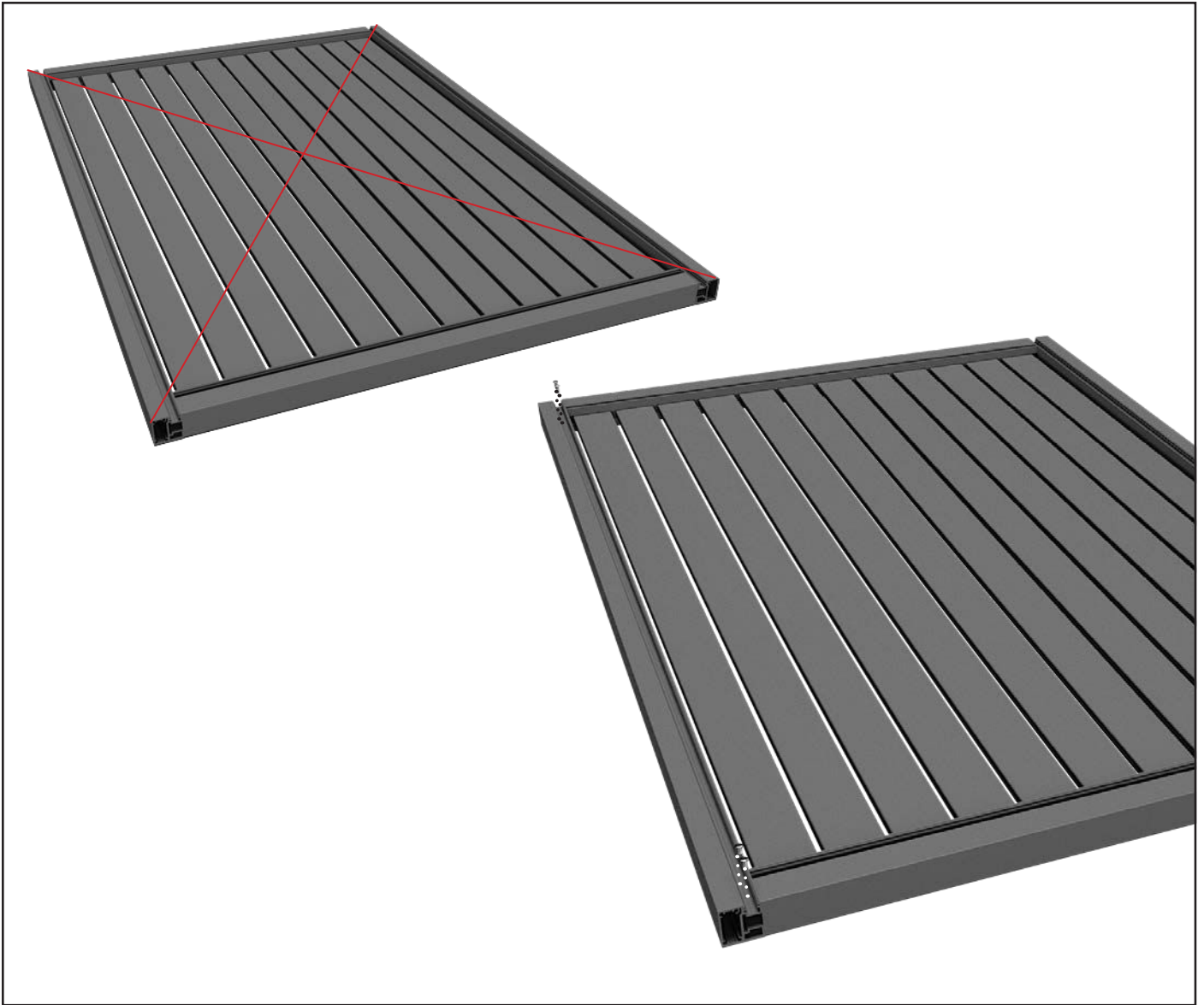

- 15 Ensure the gate is square. Pre-drill two 5mm holes through the Gate Side Frame screw channel and Joiner Blocks at top and bottom.  
Affix two 12G x 25mm long panhead screws per Joiner Block.



- 16 Ensuring the gate is square, affix each slat with two self-drilling wafer screws on each side.



- 17 For the remaining options: ii) Gate Infill, or iii) Channel Infill, affix through the Gate Side Frame screw channel using the Self-drilling Wafer Screws.

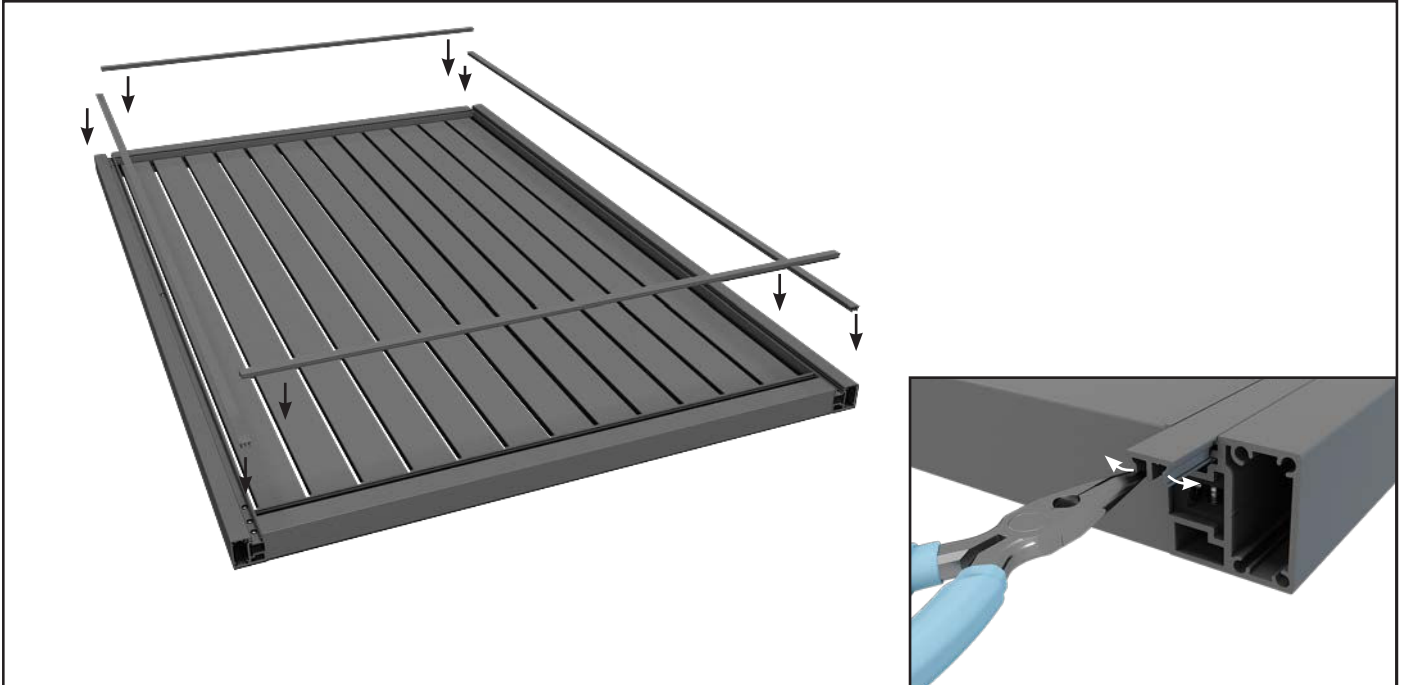

- 18 Snap the two Screw Covers into the top and bottom rails, and insert the two Screw Covers to the Gate Side Frames. Once inserted, bend the Screw Cover legs as required to achieve a tight insert.



19 Insert the two Top Caps.



● Gate Fabrication complete.