

This data sheet provides general guidance on member sizes, connections and suitable materials for the construction of handrails and balustrades. The information provided in this data sheet does not preclude the use of manufacturer's proprietary information where this satisfies the requirements of the regulatory authority.

### INTRODUCTION

For all Classes of building, handrails and balustrades are required to comply with the Building Code of Australia (BCA). The BCA requirements include design and construction provisions for the various components including compliance with the loading provisions of AS 1170.1 Structural design actions Part 1: Permanent, imposed and other actions.

For handrails and balustrades, the BCA is primarily concerned with the safety of building users and occupants. Design and construction must therefore take into consideration both the strength and durability of materials and components as well as the "geometric" constraints prescribed by the BCA to prevent people from accidentally falling through, under or over the balustrade.

The BCA should be consulted to determine where handrails and balustrades are required and for specific details regarding handrails for stairs, geometric limitations and other criteria.

### LOADS

AS 1170.1 requires balustrades and railings together with members and connections which provide structural support to be able to resist the following factored limit state loads - 0.9kN inward, outward and downward load at any point. It also requires balustrades and handrails to be able to resist factored horizontal or vertical loads of 0.53kN/m for all areas within or servicing exclusively one dwelling including stairs and landings but excluding external balconies and 1.13kN/m for external balconies in domestic and other residential buildings. Infill, including balusters, should be capable of resisting 0.75kN in any direction.

*Note: In addition, AS 1170 recommends other design loads for specific conditions such as to restrain crowds or people under panic conditions. For this case, design to resist a uniform load of 4.5kN/m is required. For these conditions, handrail and balustrade systems should be specifically designed and are not covered in this data sheet.*

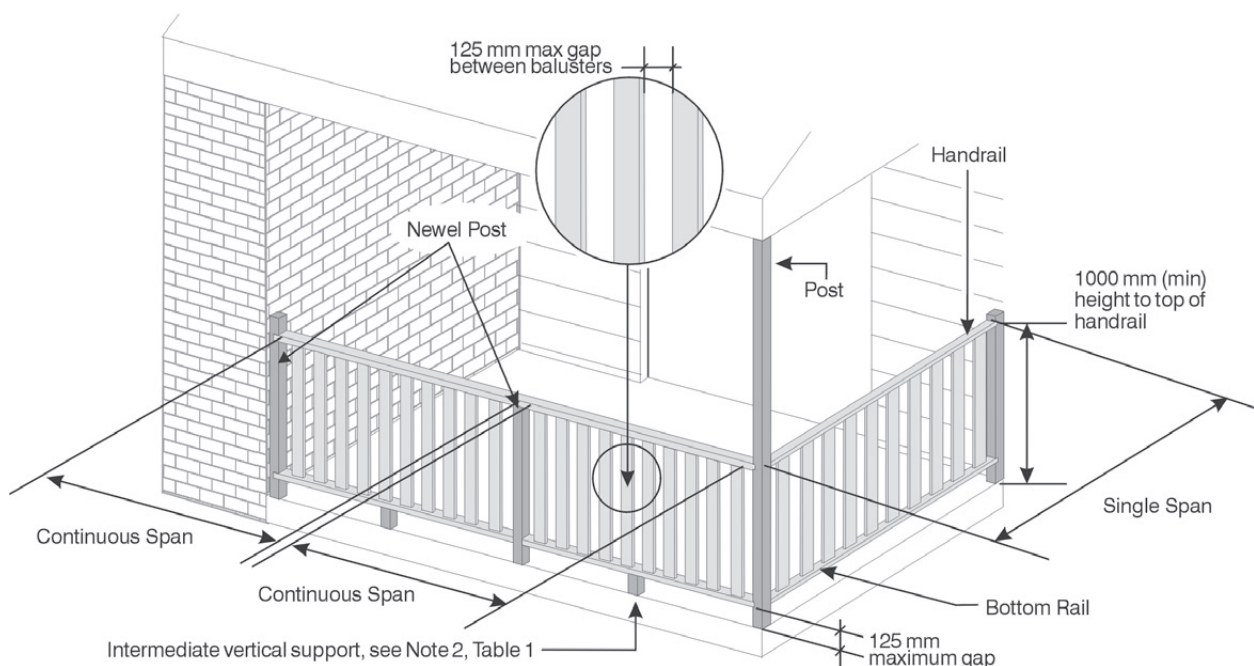

Figure 1. Balustrade terminology and dimensions

## MATERIALS (Timber - general)

### Durability

In **weather exposed** above ground applications or, where subjected to other sources of moisture, handrails, posts, newels, balusters, and infill should be either Above Ground Durability Class 1 species such as blackbutt, spotted gum, ironbark, jarrah, merbau or kwila with any sapwood present treated to H3 (or higher) or, H3 (or higher) treated softwood such as slash, Aruacana (hoop) or radiata pine. Preservative treatment shall comply with AS 1604.

*Note: Meranti, Victorian Ash and Tasmanian Oak are not suitable for weather exposed applications.*

For **internal use**, timber of any durability class is suitable.

### Timber Grade

The timber should be free from any major strength reducing features, be straight grained and be in accordance with the following:-

- Hardwood (Including Meranti) – AS 2796 – Timber - Hardwood – Sawn and milled products - Clear or select grade
- Softwood (Including imported softwood) – AS 4785 – Timber - Softwood, Sawn and milled products - Clear grade

*Note: Finger jointed timber shall comply with AS 1491 – ‘Finger jointed structural timber’ and laminated timber shall comply with AS 1328 – ‘Glued laminated structural timber’.*

## MATERIALS (Structural Properties & sizes)

### Posts / Newel Posts

Newel posts with handrails attached (handrails not greater than 1000mm from the floor) and posts connected to and restrained by the roof frame, up to 2700mm high shall be in accordance with Table 1

**TABLE 1 - POSTS**

Timber Grade	Newel Posts (external)		Full Height Posts	
	Minimum size (mm x mm)	Maximum Post Spacing (m)	Minimum size (mm x mm)	Maximum Post Spacing (m)
F8 (Softwood)	88 x 88	1.3	88 x 88	2.3
F17 (Hardwood)	90 x 90	2.7	90 x 90	3.6
F27 (Hardwood)	90 x 90	3.6	90 x 90	3.6

F8, 88 x 88 newel post used internally may be spaced up to 2.7 m.

Where posts support roof and or floor loads, refer to AS 1684 to determine minimum grade and size but shall be min F8, 88 x 88.

### Handrails

Handrail sizes and spans shall be in accordance with Table 2.

*Note:*

1. Manufacturers that use this data sheet as the basis of their design should ensure that their products satisfy Australian Standards and have the relevant minimum mechanical properties including the following:-

**Hardwood** – Stress Grade F22, (characteristic bending strength  $f'b = 65$  MPa, Modulus of elasticity  $E = 16000$  MPa) and Joint Group JD2. Examples - spotted gum, ironbark, blackbutt, kwila and merbau.

**Meranti and Australian Softwood** – (characteristic bending strength  $f'b = 25$  MPa, Modulus of elasticity  $E = 9100$  MPa) and Joint Group JD4. Examples - radiata pine, hoop pine, slash pine and meranti.

**Imported Softwood** - (characteristic bending strength  $f'b = 25$  MPa, Modulus of elasticity  $E = 6900$  MPa) and Joint Group JD4. Examples - New Zealand radiata pine.

2. Unless branded to identify that it is 'Australian Grown', softwood balustrades spans shall be determined from the 'Imported Softwood' spans given in Table 2.

### Infill / Balusters

The minimum size of infill/balusters shall be as follows:-

Hardwood - 25 x 19 mm or 25mm diameter

Softwood - 62 x 19 or 35 mm diameter

Maximum distance between intermediate supports, where required as per Note 2 Table 2.

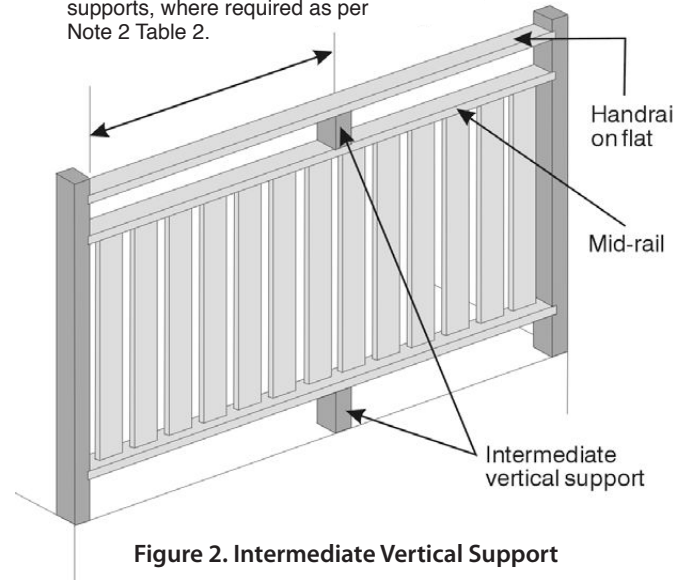

**Figure 2. Intermediate Vertical Support**

**TABLE 2 - HANDRAILS**

Timber	Size / Description	Maximum span of Handrail (mm)			
		Within or exclusively servicing one Dwelling (excluding external balconies)		Other areas in Residential Buildings (including external balconies)	
		No Intermediate Vertical Supports (1)	With Intermediate Vertical Supports (2)	No Intermediate Vertical Supports (1)	With Intermediate Vertical Supports (2)
<b>Hardwood</b>	65 x 65 (profiled)	3000	3000	3000	3000
	42 x 65 (profiled)	2200	2700	2200	2700
	42 x 85 (profiled)	2400	3400	2400	3400
	35 x 70	2100	3000	2100	3000
	35 x 90	2200	3600	2200	3600
	35 x 120	2400	3600	2400	3600
	45 x 70	2500	3200	2500	3200
	45 x 90	2700	3600	2700	3600
	45 x 120	2900	3600	2900	3600
	70 x 70	3500	3500	3500	3500
	70 x 90	3600	3600	3600	3600
	<b>Meranti and Australian Grown Softwood</b>	65 x 65 (profiled)	2700	2700	2200
42 x 65 (profiled)		1400	2000	1400	1800
42 x 85 (profiled)		1800	3000	1700	2400
35 x 70		1200	2400	1200	2000
35 x 90		1600	3200	1600	2500
35 x 120		2100	3600	1800	3400
45 x 70		2000	2800	1800	2200
45 x 90		2400	3400	2000	2900
45 x 120		2600	3600	2400	3600
70 x 70		3200	3200	2800	2800
70 x 90	3400	3600	3200	3600	
<b>Softwood Imported or Unknown Origin</b>	65 x 65 (profiled)	2400	2400	2200	2200
	42 x 65 (profiled)	1400	2000	1400	1800
	42 x 85 (profiled)	1800	2700	1700	2400
	35 x 70	1200	2400	1200	2000
	35 x 90	1600	2900	1600	2500
	35 x 120	1900	3600	1800	3400
	45 x 70	2000	2600	1800	2200
	45 x 90	2200	3100	2000	2900
	45 x 120	2300	3600	2300	3600
	70 x 70	2900	2900	2800	2800
	70 x 90	3000	3400	3000	3400

(see notes over page)

**Notes**

1. Handrails with no intermediate vertical supports may be used on flat or on edge. See Figure 3.
2. Handrails with intermediate vertical supports shall be installed on flat with intermediate vertical supports spaced not greater than the allowable spans given for the same handrail with no intermediate vertical supports. See Figures 2 and 3.
3. Where a mid-rail (minimum size 42x65) is within 150mm of the main handrail and is rigidly fixed to it (using blocks, or balusters or dowels that pass through the mid rail and are fixed to the top rail) at least once at mid span, the allowable span of the handrail may be increased by 300mm.
4. Handrail spans have been limited to 3600 mm maximum.
5. Profiled sections typically include bread loaf, ladies waist and colonial profiles.
6. There is no negative tolerance permitted on the breadth or depth dimensions (overall outside dimensions of profiled shapes) given in the above table.

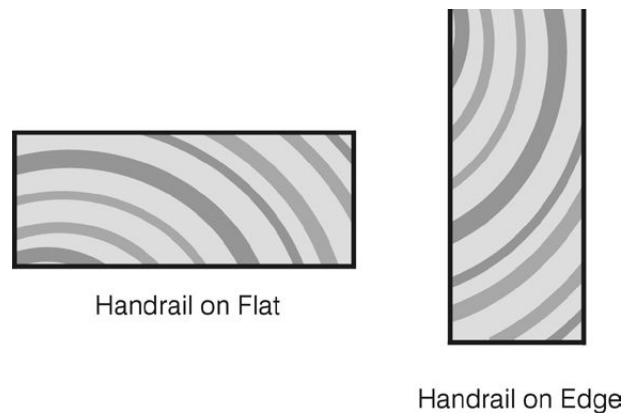

**Figure 3. Handrails - on flat / on edge**

**Corrosion Resistance**

For weather exposed applications, all metal connections including nails, screws, bolts and brackets should be a minimum of hot dipped galvanised (or for screws, Class 3 corrosion resistance as per AS 3566). For coastal environments subjected to airborne salt deposition, stainless steel or equivalent corrosion resistant metal connections should be used.

**CONNECTIONS**

**TABLE 3 - LOADS ON HANDRAILS**

Span Type	Handrail Span (mm)	Handrail Connection Loads (kN)		EXAMPLE OF DETERMINING HANDRAIL CONNECTION
		Within or exclusively servicing one Dwelling (exc. external balconies)	Other Areas in Residential Buildings (inc. external balconies)	
Single Span	1800	0.90	1.0	The shaded areas in Tables 3 and 4 provide a guide to the selection of an appropriate connection for a Class 3 Building with a continuous span softwood handrail span of 2400mm. <b>Step 1.</b> From Table 3 determine the load on the handrail = 3.4 kN <b>Step 2</b> From Table 4 and Figure 4, determine a connection with the capacity to resist 3.4 kN. <b>Step 3</b> Acceptable solutions determined from Table 4 are:- Type A connection, 1/M10 bolt or Type B connection, 2/No 10 screws or Type D connection, 2 No 14 screws per leg of bracket
	2100	0.90	1.2	
	2400	0.90	1.4	
	2700	0.90	1.5	
	3000	0.90	1.7	
	3300	0.90	1.9	
	3600	0.95	2.0	
Continuous Span	1800	1.2	2.5	
	2100	1.4	3.0	
	2400	1.6	3.4	
	2700	1.8	3.8	
	3000	2.0	4.2	
	3300	2.2	4.7	
	3600	2.4	5.1	

**TABLE 4 - CAPACITY OF HANDRAIL CONNECTIONS**

Timber	Capacity of Connections (kN)												
	Type A			Type B			Type C				Type D		Type E
	No. Bolts	Bolt Size (Cuphead)		No. Screws	Screw Size (Type 17)		Screws		Nails		2 / Screws per leg of bracket		Refer to Manufacturers specifications
M10		M12	No 10		No14	2/No 10	2/No 14	2/3. 15 dia	2/3. 75 dia	No 10	No 14		
Hardwood (JD2)	1	13	14	1	3.4	4.4	1.9	2.3	1.6	1.8	4.9	7.6	
	2	26	28	2	6.8	8.8							
Softwood and meranti (JD4)	1	8	9	1	2.0	2.6	1.1	1.3	0.9	1.0	2.8	4.3	
	2	16	18	2	4.0	5.2							

- Notes:
1. For Type B connections, minimum screw penetration into post is 38mm.
  2. For Type C connections the minimum screw penetration into post is 40mm and the minimum nail penetration into post is 38mm.
  3. Midrails and bottom rails shall be fixed with a minimum of 2 / 3.15 dia. skew nails.

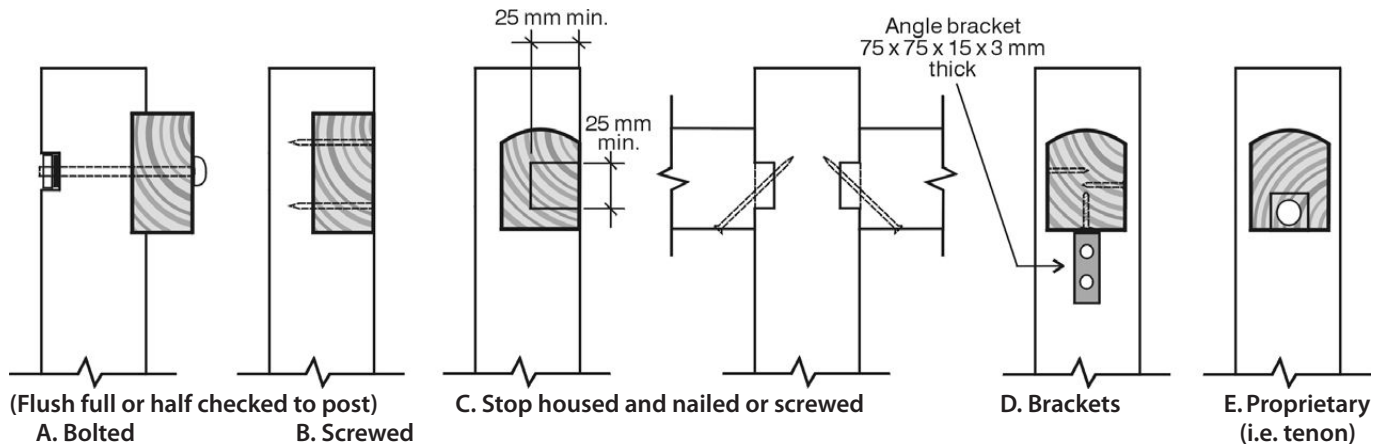

Figure 4. Handrail Connections

**TABLE 5 - CONNECTORS FOR BALUSTERS / INFILL**

Timber	Type A - Minimum Nail / Screw Penetration 'l' (mm)				Type B - Nail in shear minimum penetration 'l' (mm)
	Nails		Screws		
	2 / 2.5 dia.	2 / 2.8 dia	1 / No. 8	1 / No. 10	
Hardwood (JD2)	22	20	15	15	1 / 2.5 dia x 25 penetration
Softwood and meranti (JD4)	53	47	15	15	2 / 2.5 dia x 25 penetration

Notes: Where the balusters / infill are slotted into a groove or a dowel into a hole (i.e. top connection in Figure 5 Type A) that restrains both inward and outward forces, the above nail / screw fixing requirements are not applicable.

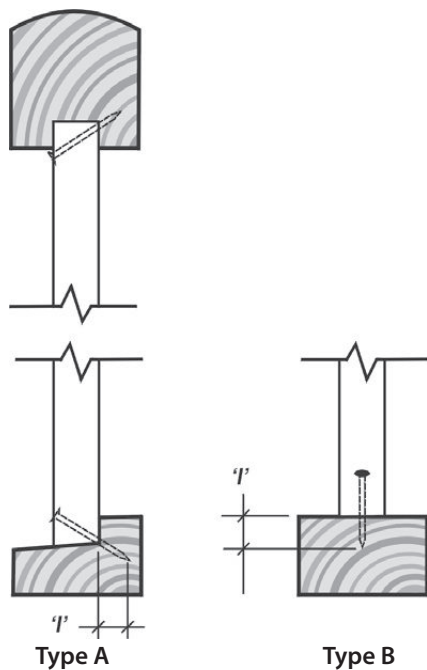

Figure 5. Balusters/Infill

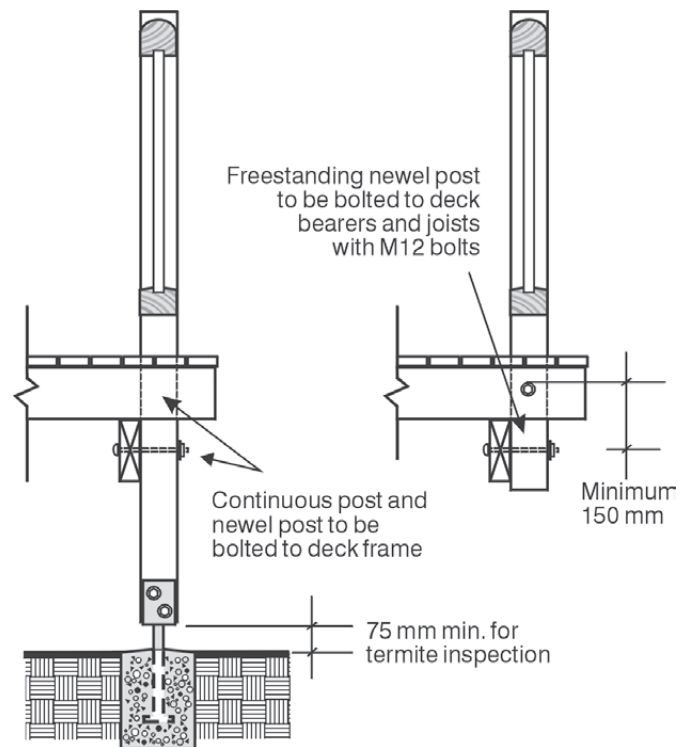

Figure 6. Post and Newel Post Connections

## PAINTING AND FINISHING – EXTERNAL

### Unprimed Timber

Nail holes should be stopped with an exterior grade wood filler.

Dirt or any loose material should be removed prior to coating.

All surfaces, ends and joints should be primed **prior to assembly** with a quality solvent based alkyd primer or stain, in accordance with manufacturers recommendations.

Final top coats of exterior paint or stain should then be applied in accordance with manufacturers recommendations.

### Pre-primed LOSP Treated Timber

Refer to TDS 24 - Recommendations for the use of H3 LOSP Treated Pine. Pre-primed handrail and balustrade components should be sanded back and dusted off to remove any loose or powdery coatings prior to finishing. Cut ends, holes, notches etc should be treated with a spray on or brush on supplementary preservative.

Nail holes should be stopped with an exterior grade wood filler.

All surfaces, ends and joints should be primed **prior to assembly** with a quality, solvent based alkyd primer.

When the primer has dried in accordance with the manufacturers recommendations, apply two full coats of premium 100% acrylic exterior topcoat in accordance with manufacturers recommendations.

## SAFE WORKING

Working with timber produces dust particles. Protection of the eyes, nose and mouth when sanding, sawing and planing is highly recommended. Refer to tool manufacturers for safe working recommendations for particular items of equipment.

## DISPOSAL OF OFFCUTS AND WASTE

For any treated timber, do not burn offcuts or sawdust.

Preservative treated offcuts and sawdust should be disposed of by approved local authority methods.



**TIMBER**  
**QUEENSLAND**  
*We build Queensland*

**Timber Queensland Limited**

ACN 092 686 756 | ABN 50 092 686 756

30 Boothby Street, Kedron  
Brisbane Queensland 4031

Phone (07) 3358 7900

Fax (07) 3358 7999

PO Box 231, Kedron Qld 4031

admin@timberqueensland.com.au

[www.timberqueensland.com.au](http://www.timberqueensland.com.au)

Whilst every effort is made to ensure the accuracy of advice given, Timber Queensland Limited cannot accept liability for loss or damage arising from the use of the information supplied.