

This data sheet contains Timber Queensland's recommendations for attached and detached timber pergolas and carports with relatively flat skillion roofs and lightweight roofing (max 10 kg/m<sup>2</sup>). It covers the most common timber species, sizes and fixing methods. Where appropriate, separate tables are provided for low wind speed areas (N1, N2, N3 and C1) and higher wind speed area (N4 and C2). Wind classification C3 is beyond the scope of this data sheet. For alternative stress grades, fixing methods, larger spans, pitched roofs, wind classification C3 etc., refer AS 1684 – Residential timber-framed construction.

*Note: The sizes and fixings assume pergolas are either roofed (lightweight roofing 10 kg/m<sup>2</sup>), or could have a roof installed at some future stage.*

### TIMBER SELECTION

Pergola and carport framing exposed to the weather, including posts fixed above ground, shall be either preservative treated pine, durability class 1 or 2 hardwood, or cypress.

Posts embedded in the ground shall be in-ground durability class 1 hardwood, preservative treated pine or cypress (sapwood free).

Hardwood posts and framing containing sapwood shall be preservative treated.

Preservative treatment for posts in the ground shall be H5. Exposed framing and posts above ground shall be treated to H3.

*Note: Lower durability timbers (e.g. Oregon, Tasmanian Oak, Victorian Ash) are not recommended for pergolas unless fully protected by a roof.*

### MEMBER SIZES

Tables 1, 2, 5 and 10 list the recommended sizes and spans for the most commonly available timber species. For alternative species and larger spans refer AS 1684.

*Note: When appropriate separate tables are provided for different wind classifications. Tables with a suffix L are for low wind speed areas (N1, N2, N3 and C1). Tables with a suffix H are for higher wind speed areas (N4 and C2).*

### FIXINGS

Fixings (stirrups, brackets, bolts, nails etc.) shall be either hot dipped galvanised or stainless steel.

Tables 3, 4, 7, 8, 9, 10, 11 and 12 contain recommended fixings between the various members. For alternative fixing methods refer AS 1684.

*Note: When appropriate separate tables are provided for different wind classifications. Tables with a suffix L are for low wind speed areas (N1, N2, N3 and C1). Tables with a suffix H are for higher wind speed areas (N4 and C2).*

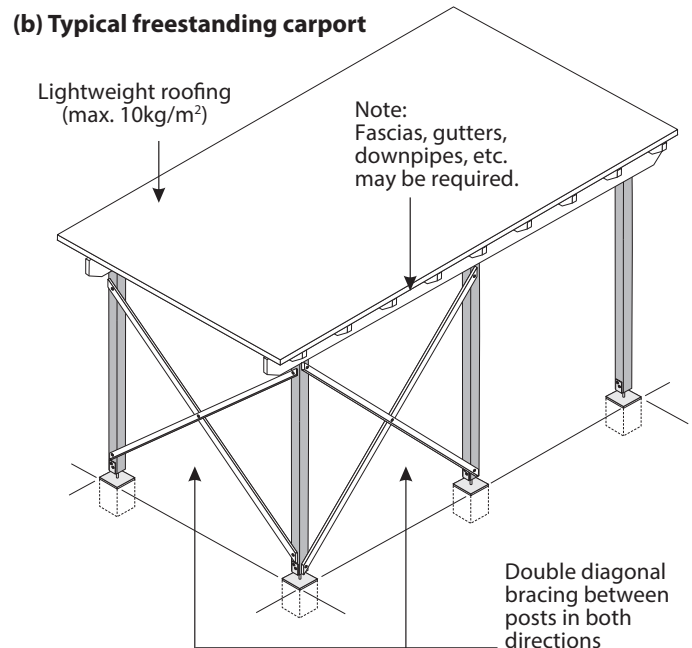
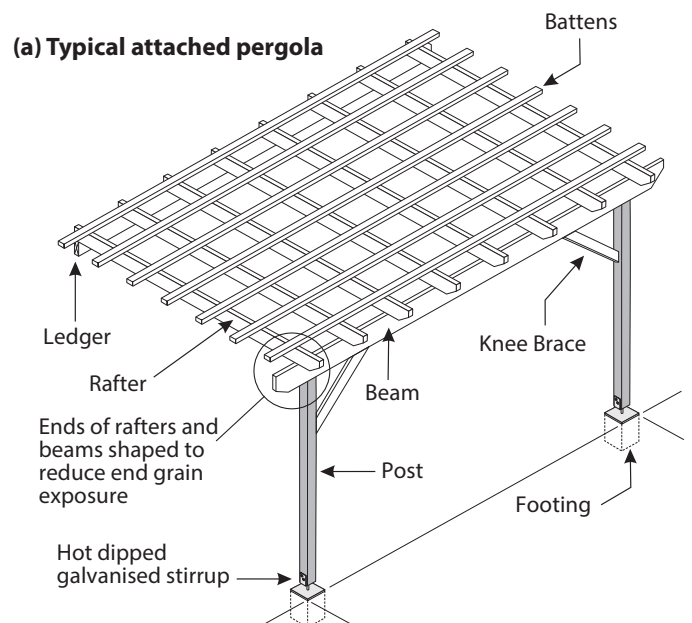

Figure 1 - Terminology

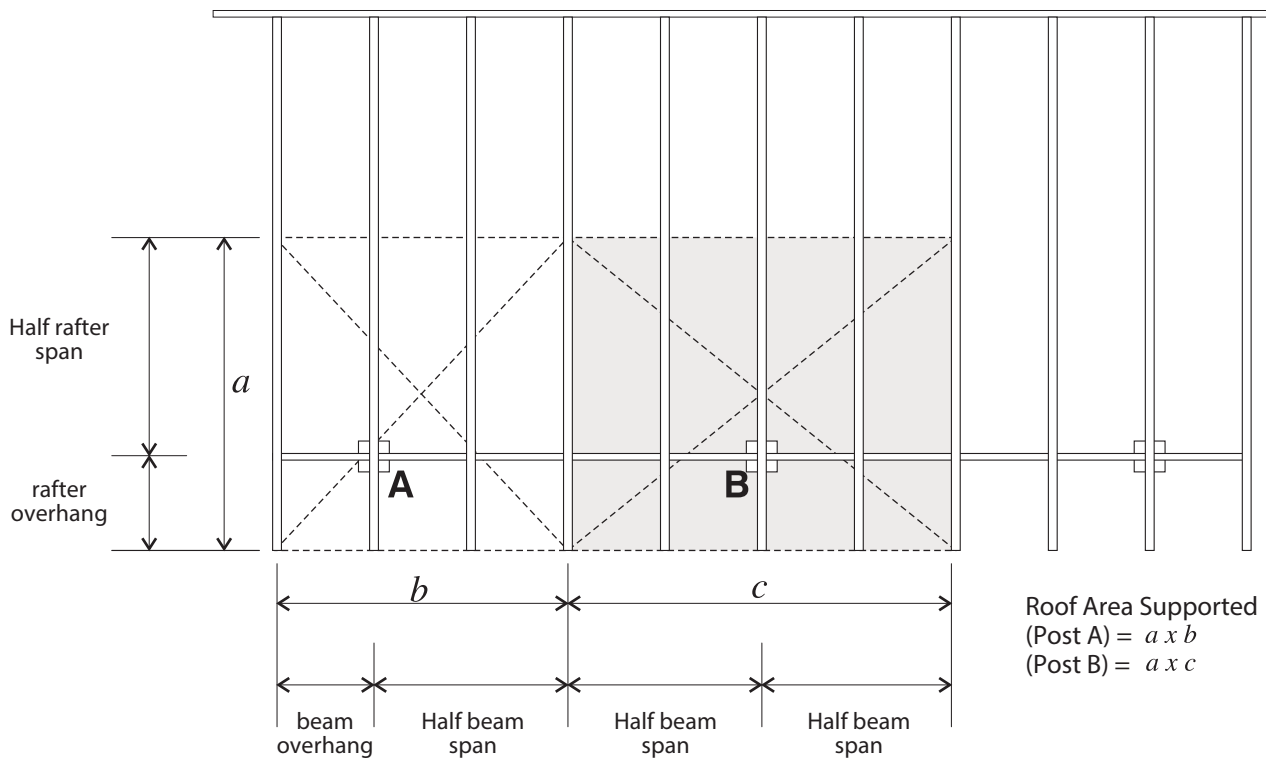

Figure 2 - Roof area supported by posts

### TIMBER POSTS

Table 1 lists the sizes for timber posts.

**TABLE 1 - TIMBER POSTS - SUPPORTING PERGOLA OR CARPORT ROOF (MAX. 10 KG/M<sup>2</sup>)**

	Roof Area Supported (m <sup>2</sup> )	5	10	20
	Member Size (mm)	Maximum Post Height (mm)		
Unseasoned Cypress F5	75 x 75	3400	2400	N/S
	100 x 100	4800	4200	3000
Seasoned Treated Pine F7	70 x 70	3500	2500	N/S
	90 x 90	4800	4100	2900
Unseasoned Hardwood F14	75 x 75	4800	3400	2400
	100 x 100	4800	4800	4200
Treated Pine Rounds F8	100 dia	4800	3400	N/S
	125 dia	4800	4800	3600
	150 dia	4800	4800	4800

### ATTACHING POSTS TO TIMBER DECKS

Posts supporting roofs or pergolas over timber decks shall occur directly over deck supports. Posts supporting decks and roofs may be continuous from ground to roof beams with deck bearers fixed to sides of posts (refer Technical Data Sheet 4). Alternatively, posts supporting roofs shall be fixed to bearers with the required fixing type listed in Tables 3 and 4.

### INSTALLING POSTS IN GROUND

Sawn timber posts should preferably be fixed to hot dipped galvanised steel stirrups set in concrete. A minimum clearance of 75 mm shall be provided between the top of the concrete footing or paving and the bottom of the post as a termite inspection zone.

Posts embedded in the ground shall be provided with stainless steel mesh socks (TermiMesh) or alternatively the surrounding ground shall be chemically treated.

Holes for embedded posts shall be filled with 100 mm depth of coarse gravel (to allow water to drain) before backfilling with concrete or rammed earth. Top of backfill shall be sloped away from posts to shed water. Footings to be engineer designed for both bearing and uplift.

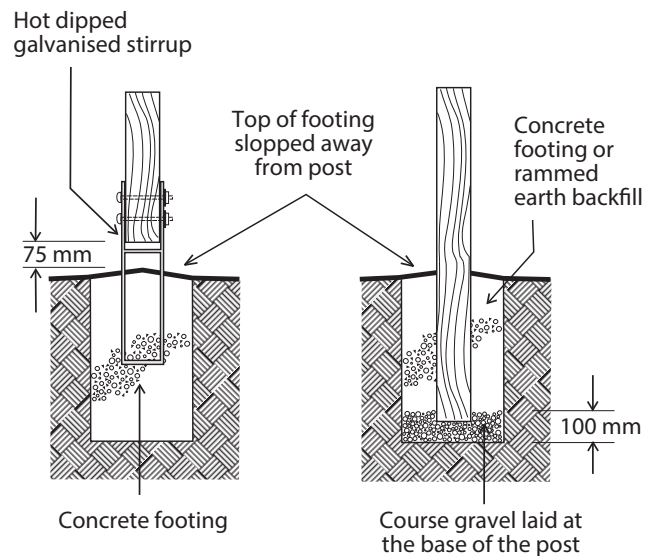

(a) Fixed to stirrup

(b) Embedded in ground

Figure 3 - Installing posts

## PERGOLA OR CARPORT BEAMS

Tables 2L and 2H list the sizes and spans for pergola or carport beams in low wind speed and higher wind speed areas.

### TABLE 2L - PERGOLA OR CARPORT BEAMS - (WIND CLASSIFICATIONS N1, N2, N3 AND C1)

	Member Size	Roof Load Width							
		1500	3000	4500	6000	1500	3000	4500	6000
		Maximum Beam Span (mm)							
		Single Span				Continuous Span			
Unseasoned Cypress F5	100 x 50	N/S	N/S	N/S	N/S	1800	N/S	N/S	N/S
	100 x 75	1700	N/S	N/S	N/S	2300	1600	N/S	N/S
	125 x 50	1800	N/S	N/S	N/S	2500	1600	N/S	N/S
	125 x 75	2800	1800	N/S	N/S	2900	1900	1600	N/S
	150 x 50	2800	1700	N/S	N/S	2900	1900	1600	N/S
	150 x 75	3200	2300	1700	N/S	3400	2600	1900	1700
	175 x 50	3200	2200	1600	N/S	3300	2300	1900	1600
	175 x 75	3700	2800	2200	1800	4100	2900	2300	1900
	200 x 50	3700	2600	2100	1600	3800	2700	2100	1900
	200 x 75	4200	3100	2600	2200	4700	3300	2700	2200
Seasoned Treated Pine F7	90 x 45	N/S	N/S	N/S	N/S	1800	N/S	N/S	N/S
	120 x 45	2000	N/S	N/S	N/S	2600	1700	N/S	N/S
	140 x 45	2800	1800	N/S	N/S	2900	1900	1600	N/S
	2/140 x 35	3700	2600	2100	1500	3800	2700	2100	1900
	190 x 45	3800	2700	2100	1600	3900	2800	2100	1900
	2/190 x 35	4800	3500	2900	2500	5300	3600	3000	2700
	240 x 45	4900	3300	2700	2300	5100	3400	2900	2400
	2/240 x 35	5600	4600	3600	3100	6700	4600	3800	3200
Unseasoned Hardwood F14	100 x 50	2000	1900	N/S	N/S	3000	2100	1700	N/S
	100 x 75	2700	2200	1900	N/S	3600	2700	2000	1800
	125 x 50	2900	2500	2000	1500	3800	2700	2100	1900
	125 x 75	3200	2800	2500	2200	4300	3200	2700	2300
	150 x 50	3500	2900	2600	2100	4500	3200	2700	2200
	150 x 75	3800	3300	2900	2700	4900	4000	3200	2800
	175 x 50	4000	3400	3000	2600	5000	3800	3100	2700
	175 x 75	4300	3800	3400	3100	5300	4600	3700	3200
	200 x 50	4400	3800	3400	2900	5500	4400	3500	3100
	200 x 75	4700	4200	3900	3600	5800	5300	4300	3700
	250 x 50	5100	4600	4200	3700	6300	5500	4500	3800
	250 x 75	5400	4900	4600	4300	6700	6100	5500	4700

Note: Maximum overhang shall be 25% of the actual backspan.

### TABLE 2H - PERGOLA OR CARPORT BEAMS - (WIND CLASSIFICATIONS N4 AND C2)

	Member Size	Roof Load Width							
		1500	3000	4500	6000	1500	3000	4500	6000
		Maximum Beam Span (mm)							
		Single Span				Continuous Span			
Unseasoned Cypress F5	100 x 50	N/S	N/S	N/S	N/S	N/S	N/S	N/S	N/S
	100 x 75	N/S	N/S	N/S	N/S	1800	N/S	N/S	N/S
	125 x 50	1600	N/S	N/S	N/S	1900	N/S	N/S	N/S
	125 x 75	2200	N/S	N/S	N/S	2500	1600	N/S	N/S
	150 x 50	2200	N/S	N/S	N/S	2300	1600	N/S	N/S
	150 x 75	2700	1700	N/S	N/S	2800	1900	1600	N/S
	175 x 50	2600	1600	N/S	N/S	2800	1900	N/S	N/S
	175 x 75	3200	2200	1500	N/S	3300	2300	1900	1600
	200 x 50	3000	2100	N/S	N/S	3100	2100	1700	N/S
	200 x 75	3700	2600	2000	1500	3800	2700	2100	1800
Seasoned Treated Pine F7	90 x 45	N/S	N/S	N/S	N/S	N/S	N/S	N/S	N/S
	120 x 45	1700	N/S	N/S	N/S	1900	N/S	N/S	N/S
	140 x 45	2200	N/S	N/S	N/S	2300	1600	N/S	N/S
	2/140 x 35	3000	2000	N/S	N/S	3100	2100	1700	N/S
	190 x 45	3000	2100	N/S	N/S	3200	2100	1800	N/S
	2/190 x 35	4200	2900	2300	1900	4300	3000	2600	2000
	240 x 45	3900	2700	2200	1700	4000	2800	2200	1900
	2/240 x 35	5300	3600	2900	2600	5400	3700	3100	2700
Unseasoned Hardwood F14	100 x 50	2000	N/S	N/S	N/S	2600	1700	N/S	N/S
	100 x 75	2700	1900	N/S	N/S	3000	2000	1700	N/S
	125 x 50	2900	2000	N/S	N/S	3100	2100	1700	N/S
	125 x 75	3200	2600	2000	1500	3700	2700	2100	1800
	150 x 50	3500	2600	2000	1500	3700	2700	2000	1800
	150 x 75	3800	3000	2500	2100	4600	3200	2700	2200
	175 x 50	4000	2900	2400	2000	4400	3100	2600	2100
	175 x 75	4300	3600	2900	2600	5300	3700	3100	2700
	200 x 50	4400	3400	2800	2400	5100	3500	2900	2600
	200 x 75	4700	4200	3300	2900	5800	4300	3400	3000
	250 x 50	5100	4400	3500	3000	6300	4500	3600	3100
	250 x 75	5400	4900	4400	3700	6700	5400	4400	3800

Note: Maximum overhang shall be 25% of the actual backspan.

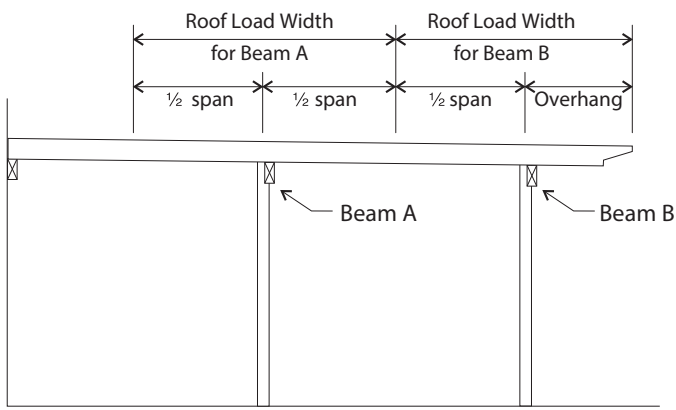

Figure 4 - Roof load width

### FIXING BEAMS TO POSTS

Beams shall be fixed to posts as listed in Tables 3 & 4. Where beams are housed into posts, a minimum of 35 mm of post shall remain. Alternatively, beams can be fixed to posts with proprietary galvanised steel brackets in accordance with manufacturer's recommendations.

### MULTIPLE BEAMS

Where covered by a roof, double beams may be either spaced apart (with a solid timber separating block at mid-span) or nail laminated together to form a single beam. Fully exposed double beams in unroofed pergolas shall be spaced.

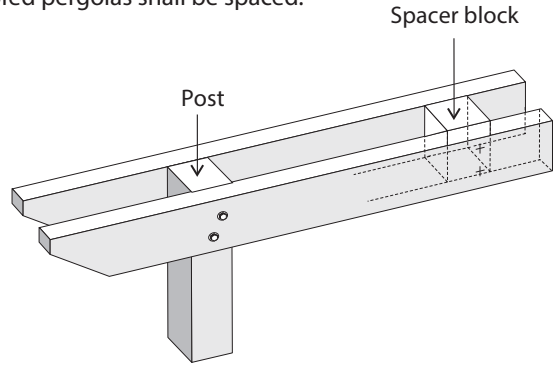

Figure 5 - Multiple beams

TABLE 3 - FIXING TYPES - POSTS TO BEARERS OR BEAMS

	Fixing Type	Description
	P1 P2 P3 P4	1/M10 bolt 1/M12 bolt 2/M10 bolts 2/M12 bolts
	P5 P6 P7	2/M10 bolts 2/M12 bolts 2/M16 bolts

TABLE 4L - FIXING REQUIREMENTS - POSTS TO BEARERS OR BEAMS (WIND CLASSIFICATIONS N1, N2, N3 AND C1)

	Roof Area Supported (m <sup>2</sup> )			
	5	10	15	20
	Fixing types permitted			
Unseasoned Cypress F5 (J3)	P4 P5	P5	P6	P7
Seasoned Treated Pine F7 (JD4)	P3 P5	P5	P6	P6
Unseasoned Hardwood F14 (J2)	P1 P5	P5	P6	P7

Note: For roof area supported refer Figure 2.

TABLE 4H - FIXING REQUIREMENTS - POSTS TO BEARERS OR BEAMS (WIND CLASSIFICATIONS N4 AND C2)

	Roof Area Supported (m <sup>2</sup> )			
	5	10	15	20
	Fixing types permitted			
Unseasoned Cypress F5 (J3)	P5	P6	P7	P7
Seasoned Treated Pine F7 (JD4)	P5	P6	P7	P7
Unseasoned Hardwood F14 (J2)	P4 P5	P6	P7	P7

Note: For roof area supported refer Figure 2.

## PERGOLA OR CARPORT RAFTERS

Tables 5L and 5H list the sizes and spans for pergola or carport rafters in low wind speed and higher wind speed areas.

**TABLE 5L - PERGOLA OR CARPORT RAFTERS - (WIND CLASSIFICATION N1, N2, N3 AND C1)**

	Member Size	Rafter Spacing			
		600	900	600	900
		Maximum Rafter Span (mm)			
		Single Span		Continuous Span	
Unseasoned Cypress F5	100 x 38	2000	1800	2400	2200
	100 x 50	2300	2100	3000	2500
	125 x 38	3000	2800	3600	2800
	125 x 50	3400	3100	4200	3300
	150 x 38	3800	3400	4400	3500
	150 x 50	4000	3700	5100	4000
	175 x 38	4300	4000	5200	4100
	175 x 50	4600	4200	6000	4800
	200 x 38	4900	4500	6000	4800
	200 x 50	5100	4800	6900	5500
Seasoned Treated Pine F7	90 x 35	1900	1800	2400	2200
	90 x 45	2200	2000	2700	2500
	120 x 35	3200	3000	3800	3000
	120 x 45	3800	3400	4300	3400
	140 x 35	4300	3500	4500	3500
	140 x 45	4800	4000	5100	4000
	190 x 35	5900	4900	6100	4900
	190 x 45	6200	5600	7000	5600
	240 x 35	7200	6200	7200	6200
	240 x 45	7200	7100	7200	7100
Unseasoned Hardwood F14	100 x 38	2700	2500	3500	3200
	100 x 50	3200	3000	4300	3900
	125 x 38	3700	3400	5100	4700
	125 x 50	3900	3700	5400	5000
	150 x 38	4400	4100	6000	5500
	150 x 50	4600	4300	6300	5900
	175 x 38	5000	4700	6800	6300
	175 x 50	5200	4900	7100	6700
	200 x 38	5600	5200	7200	7100
	200 x 50	5800	5500	7200	7200
	250 x 38	6700	6300	7200	7200
	250 x 50	7000	6600	7200	7200

Notes: For unnotched rafters, maximum overhang shall be 25% of the actual backspan.  
For notched rafters, overhang limits shall be in accordance with AS 1684.

**TABLE 5H - PERGOLA OR CARPORT RAFTERS - (WIND CLASSIFICATION N4 AND C2)**

	Member Size	Rafter Spacing			
		600	900	600	900
		Maximum Rafter Span (mm)			
		Single Span		Continuous Span	
Unseasoned Cypress F5	100 x 38	2000	1700	2300	1700
	100 x 50	2300	2000	2600	2000
	125 x 38	2900	2200	2900	2200
	125 x 50	3400	2600	3400	2600
	150 x 38	3500	2800	3500	2800
	150 x 50	4000	3200	4100	3200
	175 x 38	4200	3300	4200	3300
	175 x 50	4600	3800	4800	3800
	200 x 38	4800	3800	4800	3800
	200 x 50	5100	4400	5600	4400
Seasoned Treated Pine F7	90 x 35	1900	1700	2200	1700
	90 x 45	2200	2000	2600	2000
	120 x 35	3000	2400	3000	2400
	120 x 45	3500	2700	3500	2700
	140 x 35	3600	2800	3600	2800
	140 x 45	4100	3200	4100	3200
	190 x 35	4900	3900	4900	3900
	190 x 45	5600	4500	5600	4500
	240 x 35	6300	5000	6300	5000
240 x 45	7200	5700	7200	5700	
Unseasoned Hardwood F14	100 x 38	2700	2500	3500	3000
	100 x 50	3200	3000	4300	3400
	125 x 38	3700	3400	4800	3800
	125 x 50	3900	3700	5400	4400
	150 x 38	4400	4100	5800	4600
	150 x 50	4600	4300	6300	5300
	175 x 38	5000	4700	6800	5500
	175 x 50	5200	4900	7100	6300
	200 x 38	5600	5200	7200	6300
	200 x 50	5800	5500	7200	7200
	250 x 38	6700	6300	7200	7200
	250 x 50	7000	6600	7200	7200

Notes: For unnotched rafters, maximum overhang shall be 25% of the actual backspan.  
For notched rafters, overhang limits shall be in accordance with AS 1684.

## ATTACHING PERGOLA OR CARPORT TO HOUSE

Provided the wall frame of the house is checked to ensure it can carry the additional load, pergolas and carports can be attached to the wall (refer method W1).

Provided the wall frame is adequate, and the house roof frame and tie-down fixings are checked and increased where necessary to ensure it can carry the additional load, and withstand the additional uplift (refer Table 6), pergolas and carports can be attached to fascias/eaves.

Pergolas and carports may be attached to the fascias/eaves by methods F1, F2 and F3 as allowed in Table 7L and 7H.-

- The maximum overhang of house rafters or trusses shall not exceed 750 mm from outside of top plate to end of rafter/ truss.
- For sheet roofed houses with 900 mm rafter spacing in wind classification N4 or C2, the minimum size of F5 or MGP 10 rafters (or top chords) shall be 90 x 45 mm. In all other cases, the minimum size of house rafters (or top chords) shall be 90 x 35 mm.
- Timber fascias shall be minimum 190 x 25 mm.
- Metal fascias shall be stiffened with 150 x 50 mm nogging and 100 x 38 mm ledger as shown on detail.
- Pergola or carport rafters may be notched up to 1/3 their depth.
- Maximum pergola or carport rafter spacing shall be 900 mm.

**TABLE 6 - ADDITIONAL UPLIFT FORCE FROM CARPORT/PERGOLA**

Wind Classification	Additional uplift (kN) for carport or pergola rafter spans				
	1800	2400	3000	3600	4200
N1 & 2	0.9	1.2	1.4	1.7	2.0
N3 C1	1.4	1.9	2.3	2.8	3.3
N4 C2	2.1	2.3	3.5	4.2	4.9

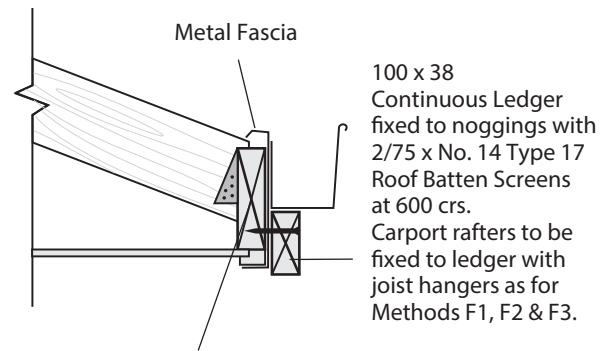

150 x 50 (140 x 45) Nogging fixed between each rafter / truss with 2/75 x 3.15Ø nails or framing anchor each end.

**Figure 6 - Metal Fascias**

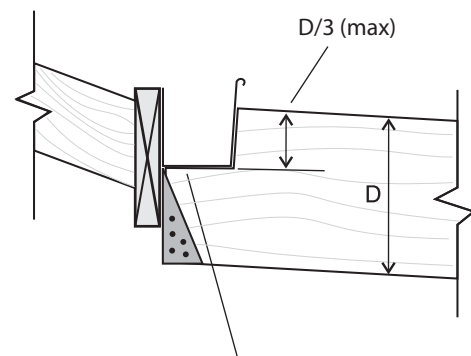

Ensure properly sealed / primed before fixing in place.

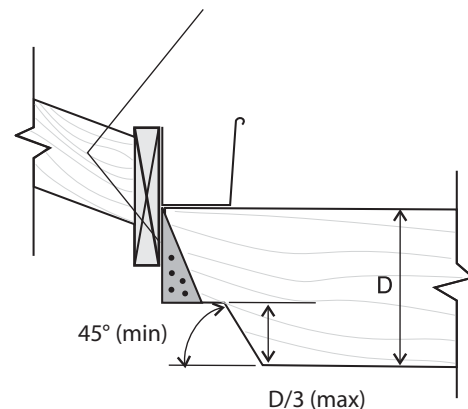

**Figure 7 - Maximum notching**

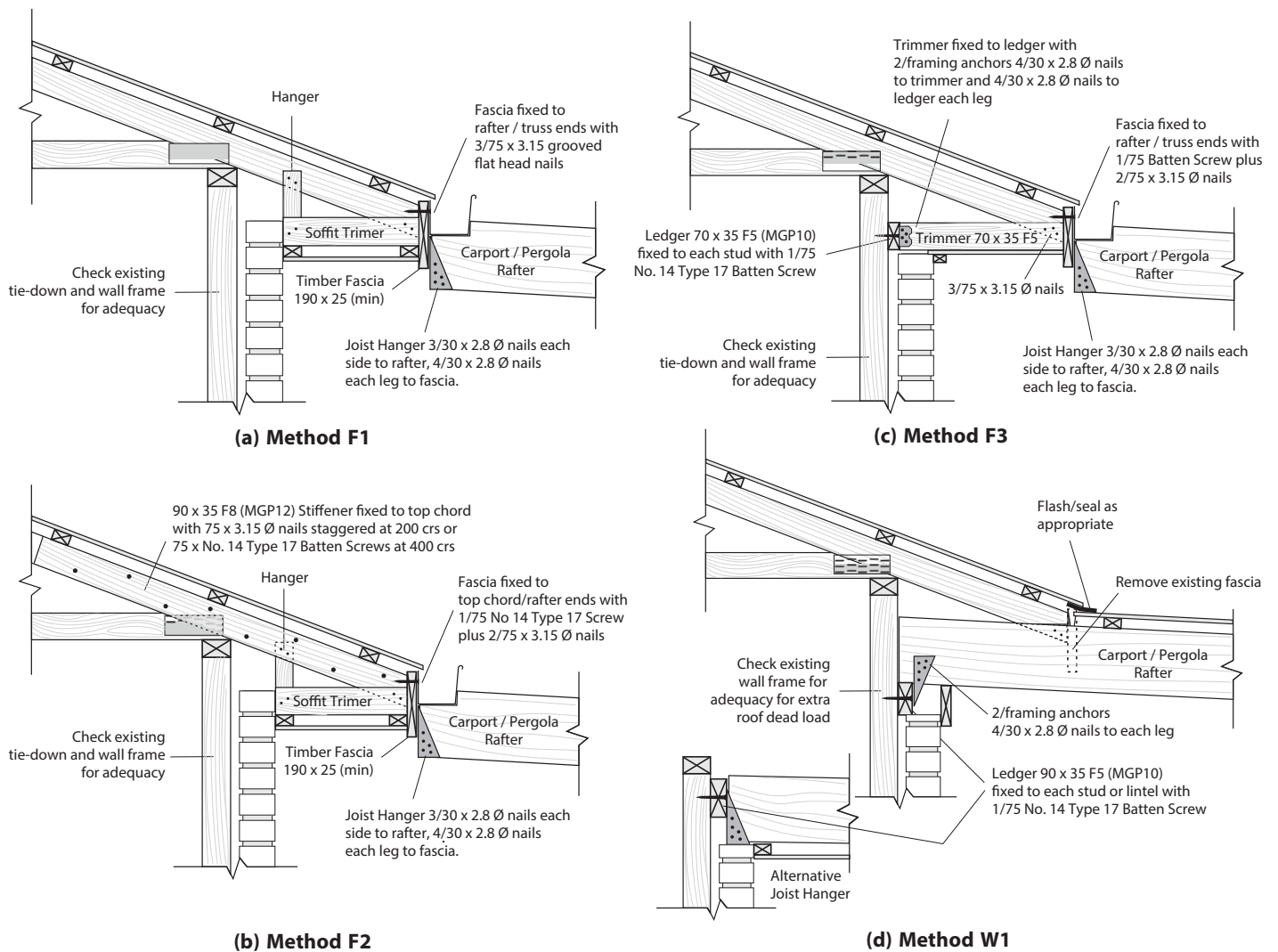

Figure 8 - Methods for attaching pergola and carport to house

TABLE 7L - ATTACHING PERGOLA OR CARPORT TO HOUSE (WIND CLASSIFICATIONS N1, N2, N3 AND C1)

House Roof		Acceptable method of attachment			
Roof Type (rafter spacing)	Rafter/Truss Stress Grade	Pergola/carport rafter span (mm)			
		2400	3000	3600	4200
Tile (600 mm)	F5 (MGP 10)	F2 F3 W1	F2 F3 W1	F2 F3 W1	F3 W1
	F8 (MGP 12) or better	F1 F2 F3 W1	F2 F3 W1	F2 F3 W1	F3 W1
Sheet (900 mm)	F5 (MGP 10)	F2 F3 W1	F3 W1	F3 W1	F3 W1
	F8 (MGP 12) or better	F2 F3 W1	F3 W1	F3 W1	F3 W1

Note: Method F1 may also be used (in wind classifications N1 and N2 only) for F5 (MGP10) pergola or carport rafters up to 2700 mm span, and for F8 (MGP12) or better pergola or carport rafters up to 4200 mm span.

TABLE 7H - ATTACHING PERGOLA OR CARPORT TO HOUSE (WIND CLASSIFICATIONS N4 AND C2)

House Roof		Acceptable method of attachment	
Roof Type (rafter spacing)	Rafter/Truss Stress Grade	Pergola/carport rafter span (mm)	
		Up to 2700	Exceeding 2700
Tile (600 mm)	F5 (MGP 10)	F3 W1	W1
	F8 (MGP 12) or better	F3 W1	W1
Sheet (900 mm)	F5 (MGP 10)	F3 W1	W1
	F8 (MGP 12) or better	F3 W1	W1

## FIXING RAFTERS TO BEAMS OR LEDGERS

Pergola and carport rafters shall be fixed to beams with the fixing type listed in Tables 8 and 9.

**TABLE 8 - FIXING TYPES - RAFTERS TO PERGOLA OR CARPORT BEAMS**

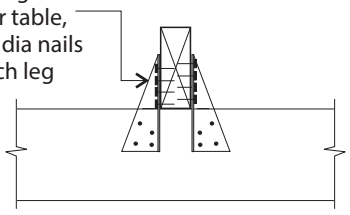
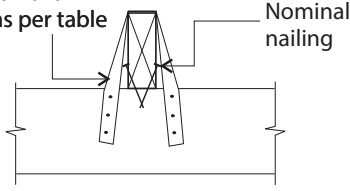
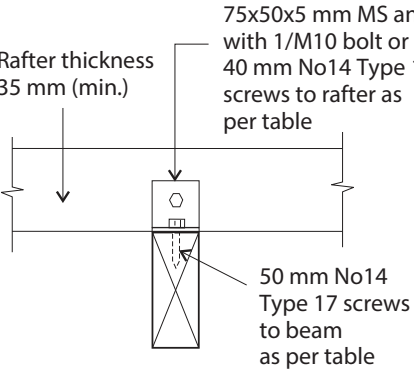
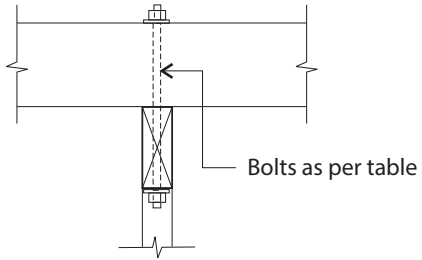
Fixing Type	Description	
Framing anchors as per table, 4/2.8 dia nails in each leg 	R1	1/galvanised framing anchor
	R2	2/galvanised framing anchors
30x0.8 mm strap with 3/2.8 mm Ø nails each end as per table 	R3	1/30 x 0.8 mm galvanised iron strap
	R4	2/30 x 0.8 mm galvanised iron strap
Rafter thickness 35 mm (min.) 75x50x5 mm MS angle with 1/M10 bolt or 40 mm No14 Type 17 screws to rafter as per table 	R5	Fixings to each leg 1/No.14 Type 17 screw
	R6	2/No.14 Type 17 screw
	R7	1/M10 bolt
	R8	1/M10 bolt
	R9	1/M12 bolt

**TABLE 9L - FIXING REQUIREMENTS - RAFTERS TO PERGOLA OR CARPORT BEAMS (WIND CLASSIFICATIONS N1, N2, N3 AND C1)**

	Roof Area Supported (m <sup>2</sup> )		
	2	4	6
	Fixing types permitted		
Unseasoned Cypress F5 (J3)	R1 R3 R5 R8	R4 R6 R8	R8
Seasoned Treated Pine F7 (JD4)	R1 R3 R5 R8	R4 R6 R8	R9
Unseasoned Hardwood F14 (J2)	R1 R3 R5 R8	R2 R4 R6 R8	R4 R6 R8

**TABLE 9H - FIXING REQUIREMENTS - RAFTERS TO PERGOLA OR CARPORT BEAMS (WIND CLASSIFICATIONS N4 AND C2)**

	Roof Area Supported (m <sup>2</sup> )		
	2	4	6
	Fixing types permitted		
Unseasoned Cypress F5 (J3)	R2 R4 R6 R8	R8	R8
Seasoned Treated Pine F7 (JD4)	R2 R4 R6 R8	R9	R9
Unseasoned Hardwood F14 (J2)	R2 R3 R5 R8	R4 R6 R8	R8

## ROOF BATTENS

Tables 10L and 10H list the sizes and spans for roof battens in low wind speed and higher wind speed areas.

**TABLE 10L - ROOF BATTENS - SUPPORTING LIGHTWEIGHT ROOF (MAX. 10 KG/M<sup>2</sup>)  
(WIND CLASSIFICATIONS N1, N2, N3 AND C1)**

	Batten Spacing	300	600	900	1200
	Member Size (d x b)	Maximum Batten Span (mm) (rafter spacing)			
Unseasoned Cypress F5 (J3)	38 x 75	900	700	550	550
	50 x 75	900	900	900	900
	75 x 38	900	900	900	900
	75 x 50	900	900	900	900
Seasoned Treated Pine F7 (JD4)	35 x 70	900	850	650	650
	45 x 70	900	900	900	900
	70 x 35	900	900	900	900
	70 x 45	900	900	900	900
Unseasoned Hardwood F14 (J2)	25 x 50	900	N/S	N/S	N/S
	38 x 50	900	900	900	900
	38 x 75	900	900	900	900
	50 x 75	900	900	900	900

Note: Maximum overhang shall be 25% of the actual backspan.

**TABLE 10H - ROOF BATTENS - SUPPORTING LIGHTWEIGHT ROOF (MAX. 10 KG/M<sup>2</sup>)  
(WIND CLASSIFICATIONS N4 AND C2)**

	Batten Spacing	300	600	900	1200
	Member Size (d x b)	Maximum Batten Span (mm) (rafter spacing)			
Unseasoned Cypress F5 (J3)	38 x 75	900	700	550	550
	50 x 75	900	900	900	900
	75 x 38	900	900	900	900
	75 x 50	900	900	900	900
Seasoned Treated Pine F7 (JD4)	35 x 70	900	850	650	650
	45 x 70	900	900	900	900
	70 x 35	900	900	900	900
	70 x 45	900	900	900	900
Unseasoned Hardwood F14 (J2)	25 x 50	900	N/S	N/S	N/S
	38 x 50	900	900	900	900
	38 x 75	900	900	900	900
	50 x 75	900	900	900	900

Note: Maximum overhang shall be 25% of the actual backspan.

## FIXING BATTENS TO RAFTERS

Pergola and carport roof battens shall be fixed to rafters with nails, screws or framing anchors as listed in Tables 11 and 12.

**TABLE 11 - FIXING TYPES - ROOF BATTENS TO RAFTERS**

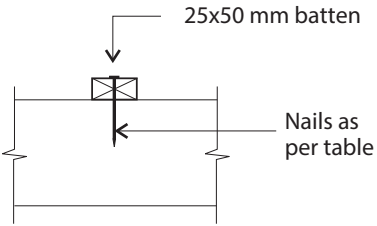
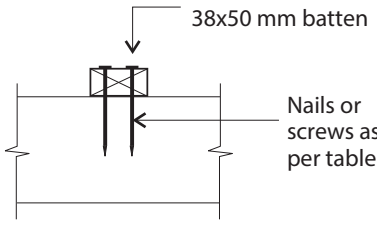
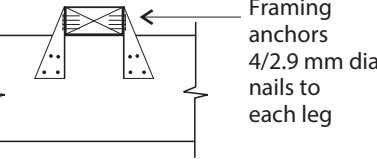
	Fixing Type	Description
	B1	1/65 x 3.05 mm dia. nail (deformed shank)
	B2 B3 B4 B5	1/75 x 3.05 mm dia. nail (deformed shank) 2/75 mm long nails (deformed shank) 1/75 mm long No.14 Type 17 screws 2/75 mm long No.14 Type 17 screws
	B6 B7	1 framing anchor 2 framing anchors (each side of batten)

**TABLE 12L - FIXING REQUIREMENTS - ROOF BATTENS TO RAFTERS (WIND CLASSIFICATIONS N1, N2, N3 AND C1)**

	Roof Area Supported (m <sup>2</sup> )				
	0.36	0.54	0.81	1.08	1.44
	Fixing types permitted				
Unseasoned Cypress F5 (J3)	B1 B3 B4 B6	B3 B4 B6	B4 B6	B4 B6	B4 B4 B7
Seasoned Treated Pine F7 (JD4)	B3 B4 B6	B4 B6	B4 B6	B4 B6	B4 B4 B7
Unseasoned Hardwood F14 (J2)	B1 B2 B4 B6	B3 B4 B6	B3 B4 B6	B4 B6	B4 B4 B6

**TABLE 12L - FIXING REQUIREMENTS - ROOF BATTENS TO RAFTERS (WIND CLASSIFICATIONS N4 AND C2)**

	Roof Area Supported (m <sup>2</sup> )				
	0.36	0.54	0.81	1.08	1.44
	Fixing types permitted				
Unseasoned Cypress F5 (J3)	B3 B4 B6	B4 B6	B4 B7	B5 B7	B5
Seasoned Treated Pine F7 (JD4)	B4 B6	B4 B6	B4 B7	B5 B7	B5
Unseasoned Hardwood F14 (J2)	B3 B4 B6	B3 B4 B6	B4 B6	B4 B6	B5 B7

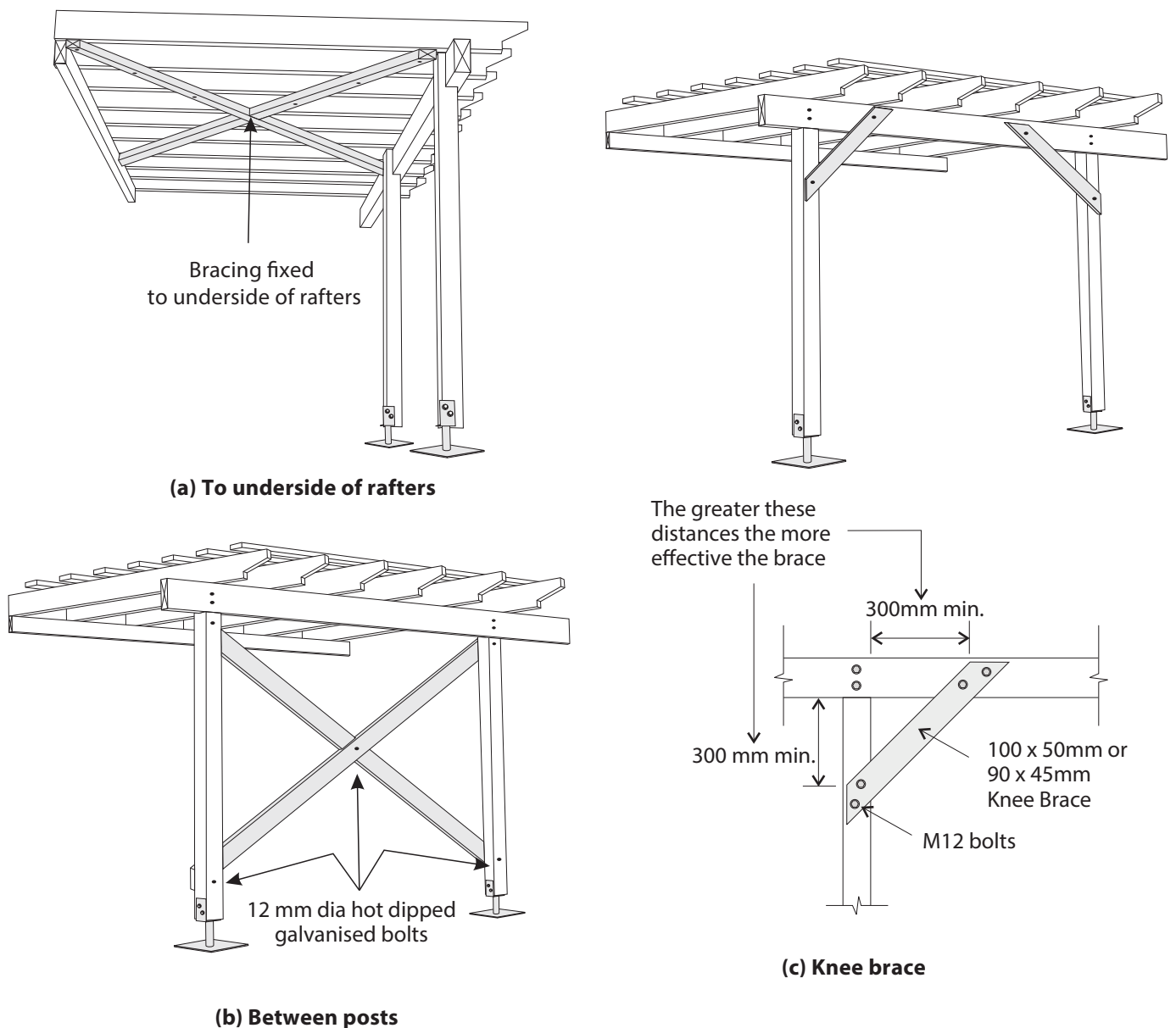

Figure 9 - Bracing

## BRACING

Carports and pergolas will require bracing to prevent lateral movement.

For pergolas attached to the house, bracing shall be either:-

- Double diagonal 100 x 50 mm hardwood or 90 x 45 treated pine braces fixed to the underside of rafters with each brace fixed to each rafter with 75 mm No. 14 Type 17 batten screws or two 75 x 3.15 mm galvanised nails, or
- Double diagonal 100 x 50 mm hardwood or 90 x 45 mm treated pine braces fixed between a pair of posts parallel to the wall, with braces bolted together at the crossing and to the posts at each end with 12 mm dia. hot dipped galvanised bolts, or
- A pair of opposing knee braces to a pair of posts parallel to the walls. Knee braces shall be 100 x 50 mm hardwood or 90 x 45 mm treated pine, fixed at approximately 45° and bolted to beams and posts with two 12 mm dia. hot dipped galvanised bolts.

Freestanding pergolas and carports require double diagonal bracing between posts in both directions (i.e. at right angles) as described in (b) above.

## ROOFING

Roof sheeting, gutters, downpipes, drainage etc. shall be installed in accordance with manufacturers recommendations and Local Authority requirements.

## FINISHING

All pergolas and carports shall have an applied finish as protection against the weathering effects of sun and rain and improve durability.

*Note: Unprotected timber exposed to the weather will fade to a silver-grey colour and could distort, split or develop surface checking.*

One coat of a water repellent preservative or an oil based primer shall be applied to concealed joints, laps etc. prior to fixing. Additional coats of the selected finish shall be applied (to manufacturer's instructions) to all surfaces after construction.

The following finish types are available:

### Clear Finishes and Water Repellent Preservatives (WRP)

These are generally water repellent materials (waxes, resins, etc.) in a light organic solvent base. They often also contain chemicals which inhibit decay. Water repellent preservatives provide good protection against moisture and are recommended as a priming coat for other coatings. The compatibility of WRP with other coatings should however be checked. Generally two weeks are required between application of WRP and other finishes.

WRP and other clear finishes do not provide long term protection against the UV effects from the sun. When used on their own they require reapplication at about six monthly intervals.

*Note: Clear polyurethane finishes can breakdown under UV exposure and are not recommended for external use.*

### Paints

Good quality, light coloured opaque paint finishes provide the best protection against weathering, however they obscure the natural colour and grain of the timber. Pale colours are recommended to reduce checking and decay.

Recoating is necessary every seven to ten years depending upon exposure. Additional preparation (sanding, repriming etc.) is frequently necessary.

### Oils/Stains

Oils and stains are available which provide a relatively natural, semi-transparent, protective finish. Stains are often available with mould inhibiting additives.

Stains with light coloured pigments are recommended as they absorb less heat and only slightly change the natural colour of the timber.

Reapplication is generally necessary every two to five years depending upon the amount of pigment included, and the degree of exposure. Apart from cleaning, no additional surface preparation is generally required.

## Maintenance

Reapplication of finishes will be required at regular intervals, depending on finish type and degree of exposure. Before recoating, all surfaces shall be thoroughly cleaned and loose dirt, grit, foliage etc. removed. For some finishes, surfaces may also require sanding. Recoating shall be carried out in accordance with the manufacturer's recommendations.

## SAFE WORKING

Working with timber produces dust particles. Protection of the eyes, nose and mouth when sanding, sawing and planing is highly recommended. Refer to tool manufacturers for safe working recommendations for particular items of equipment.

## DISPOSAL OF OFFCUTS AND WASTE

For any treated timber, do not burn offcuts or sawdust. Preservative treated offcuts and sawdust should be disposed of by approved local authority methods.



### Timber Queensland Limited

ACN 092 686 756 | ABN 50 092 686 756

30 Boothby Street, Kedron  
Brisbane Queensland 4031

Phone (07) 3358 7900

Fax (07) 3358 7999

PO Box 231, Kedron Qld 4031

admin@timberqueensland.com.au

[www.timberqueensland.com.au](http://www.timberqueensland.com.au)

*Whilst every effort is made to ensure the accuracy of advice given, Timber Queensland Limited cannot accept liability for loss or damage arising from the use of the information supplied.*