

Timber is a preferred material for landscaping purposes. Retaining walls in particular contribute significantly to the surroundings when constructed from timber. The natural appeal and versatility of timber is ideal for this application.

The purpose of this Technical Data Sheet is to provide sufficient detail to enable the correct design and construction of either log or sawn (or combinations) timber retaining walls in residential applications.

SCOPE

This document is intended to provide guidance for the design and construction of timber retaining walls in residential settings and shall not be used where design or construction exceeds any of the following limits or exclusions.

Where there is any variation to the limitations stated in this Data Sheet including materials, soil conditions, drainage, surcharge (additional loads) or geometry of the retaining wall, a structural/geotechnical engineer should be engaged to design the wall.

(i) Sloping Ground

If the ground in front of the wall is sloping then full ground support cannot be relied upon and larger posts with additional embedment will have to be used. If the slope is steeper than 10° (1 vertical to 6 horizontal) then a special design is required, and the tables herein shall not be used (See Figure 1).

Inclining the ground behind the wall (backfill) produces more vertical load due to weight of backfill. This results in higher horizontal loads (horizontal loads deriving from vertical loads).

If the ground behind the wall (backfill) has a slope steeper than 14° (1 vertical to 4 horizontal) the design tables are not applicable due to resulting higher gravity and live loads that will exceed the design loads assumed for the tables.

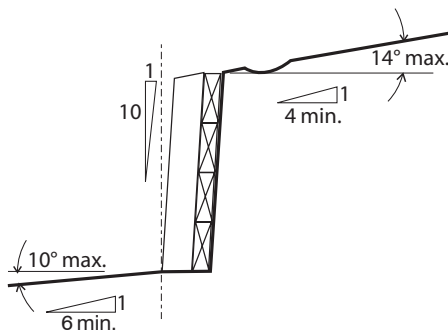

Figure 1 - Sloping ground in front of and behind wall

(ii) Permanent Structures (Existing or future)

The horizontal force generated by the vertical load of permanent structures can have significant impact on the performance of retaining structures. Permanent structures include (but are not limited to); buildings, pools, roads, parking areas, water tanks, general storage. If any such structures will impact within the zone of influence, as per Figure 3, the retaining wall design should be referred to a structural/geotechnical engineer. Fences of lightweight materials (timber, metal etc.) constructed on or above the wall do not impact on the design of the walls.

(iii) Roads or Railways

Roads and railways and areas adjacent are required to be designed for loads to accommodate the infrastructure and the vehicles over (trains, trucks etc.). These loads are significantly larger than those allowed for in this Data Sheet and therefore the Data Sheet shall not be used in these situations.

(iv) Multiple Retaining Structures

A retaining structure constructed within the zone of influence of another retaining structure will apply additional loads to the lower wall. Terraced walls require specific design by structural/geotechnical engineers. This includes installing a new retaining wall above or below an existing retaining structure. The attached tables should not be used for designing any retaining structure with an existing or future retaining structure above or below such that the upper wall impacts within the zone of influence of the lower, as per Figure 3.

(v) Services

Retaining structures constructed in locations near services require particular mention. Generally the walls are required to be designed to impart no load on the services. Additionally, local authorities have specific requirements for different types of services, including minimum clearances. Retaining walls to be constructed near service locations should be referred to the relevant local authority.

(vi) Drainage

Drainage of both the localised wall area and the surrounding topography should be considered during the planning process. Drainage investigations should establish the local groundwater levels including sources, directions of lateral flow and seasonal or tidal variations. The possibility of seepage or surface run off should also be examined. Inadequate drainage can result in overloading of the wall or scouring of the footings, either of which may lead to wall failure. Where doubt exists, a structural/geotechnical engineer should be consulted.

(vii) Poor Foundation Material

The foundation material assumed in design for this Data Sheet and attached tables is stiff clay. Stiff clay is unable to be molded. It is able to be indented only with strong downward pressure of thumb.

Acceptable alternative foundation materials are:

- Weathered rock (e.g. shale)
- Dense sand/gravel

If the foundation material is not within this range, the tables in this Data Sheet shall not be used.

(viii) Poor Backfill Material

The attached tables include three options for backfill materials. These are: sand, sandy gravel and gravel. Alternative materials may result in wall failure due to swelling of backfill or lack of drainage. If the backfill material is not within the above range, the tables shall not be used. Alternative backfill material should be referred to a structural/geotechnical engineer.

(ix) Consequence of Structural Failure

The designs contained in this Data Sheet assume Structural Classification 2 and 3 as per AS 4678, that is - 'Where failure would result in moderate damage and loss of services' for walls over 1.5m and 'Where failure would result in minimal damage and loss of access and where the wall height does not exceed 1.5m', for walls under 1.5m.

If the proposed retaining wall location has adjacent structures or facilities with post disaster functions, or failure of the wall may result in significant damage or risk of life, a structural/geotechnical engineer should be consulted.

MATERIALS

Timber may be used in sawn sizes approximating "landscape sleepers" or as logs where the round forms may be blended unobtrusively into the natural setting. In addition, proprietary timber crib wall systems are also available.

The minimum stress grade for sawn timber shall be F7 for softwood and F14 for hardwood.

Invariably the retaining wall forms part of a landscape where plants are encouraged to soften the harder elements of construction. In this environment the possibility of insect and fungal attack is high. In-ground Durability Class 1 timber species or plantation softwood timber preservative treated to H5 should therefore be used.

The heartwood of naturally durable species (durability class 1) that are suitable for retaining walls include ironbark, grey gum, tallowwood, forest red gum and bloodwood. These species are also listed as being termite resistant in accordance with AS 3660.1. Provided that the outer layers of the log (sapwood) are removed or preservative treated to H5, these timbers will perform satisfactorily for more than 25 years.

Softwoods have a wide sapwood band that can be made highly durable with CCA, ACQ or copper azole preservative treatment. H5 CCA treated softwood rounds have an expected service life of 50 years or more.

Preservative treatment shall be in accordance with AS 1604.1 except that the maximum percentage of untreated heartwood in softwoods (durability class 4) shall not exceed 20% at any cross section.

Note: Sawn softwood 'landscape sleepers' may be available with incising to improve preservative penetration into the heartwood and durability performance.

Further information on species, durability & suitability for specific applications can be obtained from 'Construction Timbers in Queensland' www.daff.qld.gov.au

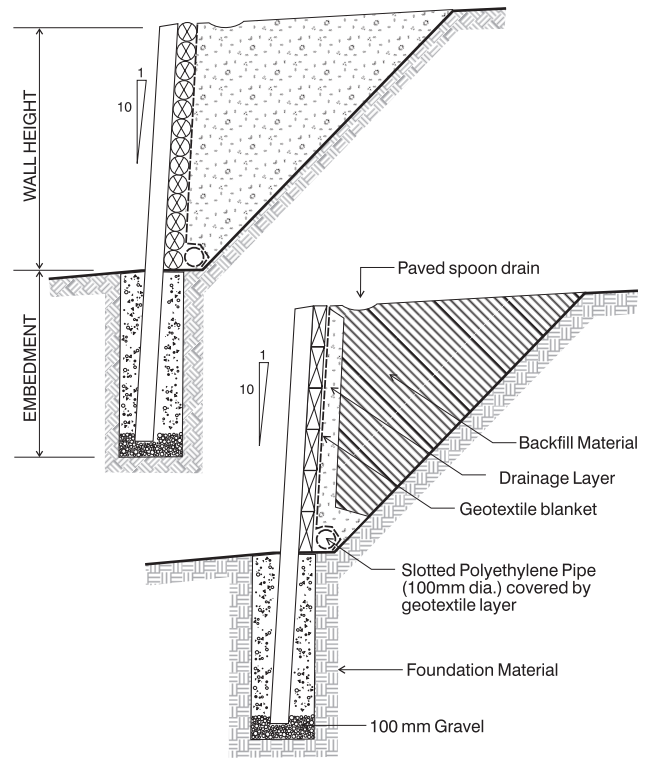

Figure 2 - Log and sleeper retaining walls

FORCES

Regardless of the construction material, it is worthwhile to understand the forces that have to be resisted so that they may be reduced to reasonable levels or allowed for in the wall design.

The vertical load of the soil, and whatever rests upon it, generates a horizontal force that the wall must resist. It follows that any increase in load must be allowed for at the design stage. This would include future:

- increase in level or slope of the backfill
- temporary loads such as dumped materials or heavy vehicles
- permanent structures such as building foundations or swimming pools (both in and above-ground)

If a typical house foundation is located within the stable zone (shown shaded in Figure 3) then it is outside the zone of influence and its presence will have a negligible effect on the stability of the wall. If this is the case, then the accompanying tables are valid, if otherwise refer to a structural/geotechnical engineer for a specific design.

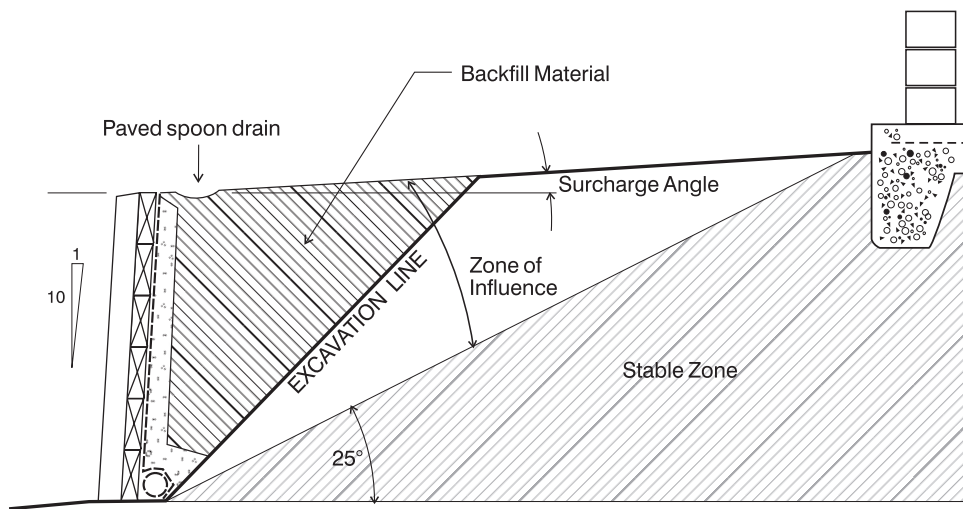

Figure 3 - Stable zone

BATTER

Gravitational forces cause the backfill to slide towards the wall. As it does so, it develops frictional forces on the sliding surface. (See Figure 4.) This significantly reduces the load to be resisted by the wall. As a result, the retaining structure can be made lighter. The wall must move before the backfill can generate its own internal friction and so the wall is erected with a batter (leans back into the bank), so that when it rotates (pressure on wall will cause it to straighten up), it still appears stable.

The battering of the face also assists in reducing the forces in several less obvious ways. Since the backfill moves horizontally during this soil creep, the surface of the soil will drop. Any paving system used here should be flexible such as masonry pavers or asphalt. - not concrete. If this lateral movement of the wall cannot be tolerated, then a stiffer wall must be designed for higher loads. It has to be emphasized that the posts are very highly stressed and that the use of undersized posts will cause excessive deflection and possibly wall failure.

DRAINAGE

A vertical layer of free draining material must be placed immediately behind the wall to dissipate the build-up of groundwater which otherwise would add to the load carried by the structure. The layer will also assist in reducing the likelihood of fine material being carried through the wall by groundwater; discoloring the face of the wall. Additionally, where the surface of the backfill drains towards the wall, a surface drain, such as a half round pipe, should be provided to prevent water spilling over the wall or seeping into the drainage blanket.

When a cut is made, the moisture of the retained soil will reduce. If the soil is reactive (changes volume with change in moisture), the soil will shrink. If a building is close by, uneven settlement may occur. Advice on this matter should be sought from a geotechnical engineer.

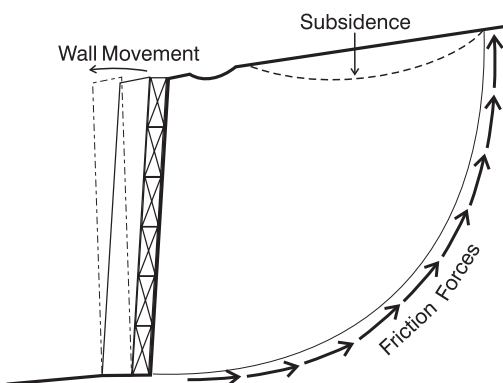

Figure 4 - Wall movement

BACKFILLING

The material behind the wall is called the backfill, and its nature determines the magnitude of the load to be carried by the wall; also, it affects the economy of the whole project. Usually it is cheaper to import backfill and save on timber and embedment costs. In any case, the drainage has to be trucked in. Generally, the more free-draining the fill, the less load is exerted.

Common backfills include gravel and sand. These materials are compacted with a minimum of effort and, as a result, there will be little settlement (consolidation) later. The worst backfill is clay which, when it wets up seasonally, generates swelling pressures whose cumulative effect causes the wall to lean forward with time. The top 150 - 200 mm of backfill may be garden soil.

FOUNDATION MATERIAL

The tables are based on the foundation material, where the post is embedded, being stiff clay or stronger, or an acceptable alternative as listed in the 'Exclusions' section.

DESIGN

The post and wale system is a versatile form of retaining wall where the posts are cantilevered out of the ground. Horizontal backing timbers (wales) transmit the soil forces to these posts.

Tables 1 to 6 may be used to determine post and wale sizes and embedment depths. Figure 5 gives typical information required for design.

Firstly determine the maximum wall height. This may be difficult as the level difference at the pre-excavation stage is not too obvious to the untrained eye. Use a string line and level or even a water level. This will also allow the quantity and lengths of timber to be accurately ordered prior to excavation.

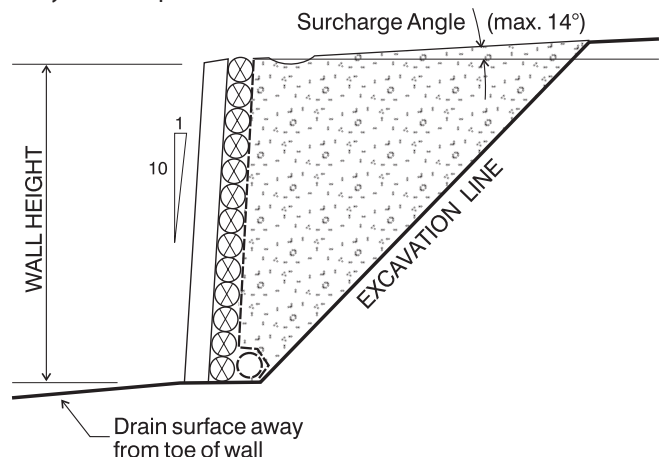

Figure 5 - Typical information for design

Select the wall type—sleeper or log or a combination of the two using materials of the required durability & target service life expectancy. Compare designs to minimize timber cost and excavation. Usually, close post spacings are best but this has to be balanced by the appearance of the finished face. Choose post spacings to suit the walings untrimmed size as all cut treated timber needs to be treated with a brushed-on preservative and, in any case, more cutting means more waste . . . and more work.

Where the ends of wales cantilever beyond the posts, wale ends are exposed. This means that the posts do not have to be accurately located resulting in less cutting and wastage. However the use of a geotextile is necessary to prevent backfill fines passing through the inevitable gaps. Where a geotextile is used, it is also recommended a suitable sand filter (~ 50 mm thick) be installed between the geotextile and the drainage material. Also this method, while using more posts, is cheaper in material cost since most of the timber volume is in the waling. Additionally, it facilitates the construction of meandering walls so that the system is more versatile in retaining the awkward shapes often necessary to obtain maximum benefit from a suburban block. The wales can also be arranged to follow the slope (especially the top) so that stepped ends are not required. If sloping wales are adopted then the wales span becomes the slope length between the posts and must be designed accordingly.

Posts can be positioned to conceal the wale joints, but this involves larger posts, deeper embedment and more care in providing even bearing of the wales onto the posts. This system is more suited to lower walls using sleeper uprights (on the flat) since this provides more bearing for the wales.

Holes for posts to 150 mm dia, should be 300 mm dia minimum. For posts above this size use 450 mm dia holes. In general try to choose posts less than 150 mm dia as they have holes 300 mm x ~ 1.6 m deep (1.5 m embedment and 0.1 m for post drainage). Tractor or 'Bob-Cat' mounted rigs can drill these holes. Larger holes require larger machines and access may be a problem.

For round posts of other strength groups other than S6, the equivalent diameters are:

S5 (Treated Slash Pine): use diameters 97% of those indicated in Tables 5 and 6.

S3 (Mixed Treated Hardwood species): use diameters 90% of those indicated in Tables 5 and 6.

e.g. A 180 mm dia S3 round is equivalent to a 200 mm dia S6 round. ($0.9 \times 200 = 180$)

Sizes over 250 mm dia in treated pine may be difficult to obtain. Lengths of sleepers greater than 2.4 m are also uncommon.

If sleepers are used for the posts, double posts are required for some walls. Where double posts occur, posts should be bolted together with galvanized M12 bolts at 400 centres for full height. If the location is within 1km of a salt-water coast (including large bays e.g. Moreton Bay) stainless steel bolts should be used.

It is possible to combine the tables using round posts together with sawn sleeper wales. Also smaller wale sizes may be used in progressing from the bottom to the top of the wall. Refer to the design example below.

Local Authorities should be consulted to ascertain if retaining walls are required to be designed and certified.

MONITORING

Monitoring of retaining walls is required to ensure the continuing safety of the structure. A program for regular monitoring of retaining walls should include:

1. Regular visual inspections
2. Inspections after events such as floods or earthquakes
3. Basic monitoring of lateral deflection.

Visual inspections should detect excessive movement, cracks or ruptures, lack of drainage capacity, physical changes and changes in the environmental conditions. The effectiveness of the drainage system should also be checked. Inspections carried out once per year may be considered 'regular' for these purposes.

It is important to note that due to the nature of sleeper retaining walls, a significant degree of rotation may be expected. This is accounted for in the design by the initial battering of the wall.

WALL DESIGN EXAMPLE

Round Posts and Rectangular Wales

Wall 1.4 m high with Single Round Treated Softwood Post system (Table 5), and Hardwood Wales (Table 1) with a horizontal backfill surface (surcharge) - Level. Assuming that the backfill will be sand, sandy gravel or gravel.

Select 2.1 m wale length for a 1.4 m high wall in Table 1. The wale size required is 200x100mm. The wale size for the top 1200mm of the wall can be reduced to 200x75 mm.

From Table 5, the post size required for a 1.4 m high wall and 2.1m wale length is 225 mm dia. Post embedment is 2000mm deep by 450 dia.

Alternatively, if the wales cantilever beyond the posts (Table 2), a wale size of 200x75 for the full height of the wall and Post size of 200 dia with footings 1700 deep x 450 mm dia is required (Table 6). This may result in a more economical wall and post sizes will be easier to procure.

Order materials specifying:

Hardwood Wales—F14, Durability Class1 timber, free of sapwood or sapwood preservative treated to H5 level.

Softwood Post — Slash or Radiata pine, CCA treated to H5 level (Most softwood is now sold in length increments of 600 mm e.g. 1.8 m, 2.4 m etc., so use these sizes for design to minimise wastage).

CONSTRUCTION

- At the setting out stage (before excavation) check that the structures above the wall, such as house foundations, are sufficiently remote not to be affected. Refer to Figure 3 for these limitations.
- Where a cut is to be retained, work should proceed quickly to minimise the chances of a slip before construction is complete.
- If retaining a cut, excavate the ground 400 mm behind the post centerline and batter at 1:1. This should be a stable slope for most temporary excavations. If in doubt seek advice from a geotechnical engineer.
- Bore the required embedment depth into firm natural ground (not fill) plus an additional 100 mm for the gravel soak-away. For posts to 150 mm dia use 300 mm dia holes and 450 mm dia holes for larger members. Regardless, where the pole tapers or construction tolerance gives less than 50 mm around the post then the hole size has to be increased. Remember that these post holes have to be bored at approximately 6° from the vertical to cater for the 1:10 batter of the wall.

- Place 100 mm gravel layer in the hole.
- Place posts to designated batter and align the backs to achieve the best line. Prop posts with timber.
- For treated softwood posts, standard 15 MPa (N15) concrete backfill is adequate.
- For hardwood posts, which have a much smaller treatment zone, backfill with no-fines concrete. The no-fines concrete shall be 10 mm maximum aggregate size, 450 kg cement/m³ and a water cement ratio of 0.55. The concrete shall be ready mixed or hand mixed manufactured to the requirements of AS 1379. For no-fines concrete, the concrete shall be well agitated immediately before placing to ensure a complete coating of the aggregate. The concrete shall be discharged directly into the holes and tamped without delay. All concrete shall be placed within 1 hour of batching. The no-fines concrete shall not be re-worked as this destroys the bond. For no-fines concrete, top the last 100 mm with clay to prevent surface infiltration into the backfill.

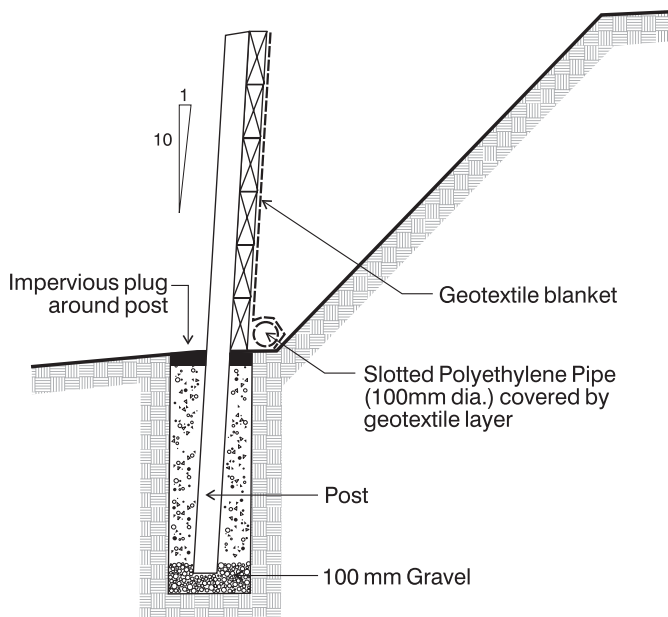

Figure 6 - Wall prior to backfilling

- Place wales behind posts and temporarily attach (nail or wire) to posts. Round wales may need to be 'end for ended' to maintain alignment and to produce a gap free wall. Slabs (rounds with two sawn parallel flats) would eliminate this problem but more timber would be used.
- Place drainage blanket (geotextile) to inside of face to prevent backfill material from flowing out small gaps and to assist in drainage. Lay a slotted polyethylene pipe at the base of the wall to an outlet (refer figure 6).

- After no-fines concrete has been placed for at least 4 days, place sand filter and backfill together. Gravel or sand backfill itself will also act as a filter eliminating the difficulty in backfilling with two materials.
- Slope pole tops to shed water. Place nail plates on exposed ends especially on round hardwood to counteract shrinkage stresses. Paint exposed ends with an end sealer to prevent intake of moisture.
- Cut and pull out the wire ties.
- Grass or pave (flexible) the backfill. Install surface drainage if slope directs water towards the wall.

If surface checking (splits) of the timber is undesirable, the exposed timber should be coated with a crystalline wax or conventional stains or paint systems.

ENGINEERING DESIGN CRITERIA AND ASSUMPTIONS

Upon written request to Timber Queensland, the engineering design criteria and assumptions used in the preparation of this Data Sheet will be provided.

Australian Standards used for design
 AS/NZS 1170.1 – Structural Design Actions,
 Part 1: Permanent, imposed and other loads.
 AS1720.1 – Timber structures – Part 1 – Design methods
 AS2159 – Piling – Design and installation
 AS4678 – Earth-retaining structures

The design relates to general Queensland conditions and should not be used in areas of different design load requirements (i.e. in Alpine areas – snow loads, or Earthquake prone areas).

SAFE WORKING

Working with timber produces dust particles. Protection of the eyes, nose and mouth when sanding, sawing and planing is highly recommended. Refer to tool manufacturers for safe working recommendations for particular items of equipment.

DISPOSAL OF OFFCUTS AND WASTE

For any treated timber, do not burn offcuts or sawdust. Preservative treated offcuts and sawdust should be disposed of by approved local authority methods.



**TIMBER
QUEENSLAND**
We build Queensland

Timber Queensland Limited

ACN 092 686 756 | ABN 50 092 686 756

30 Boothby Street, Kedron
Brisbane Queensland 4031

Phone (07) 3358 7900

Fax (07) 3358 7999

PO Box 231, Kedron Qld 4031

admin@timberqueensland.com.au

www.timberqueensland.com.au

Whilst every effort is made to ensure the accuracy of advice given, Timber Queensland Limited cannot accept liability for loss or damage arising from the use of the information supplied.

TABLE 1 - WALE JOINTS SUPPORTED AT POSTS - SAWN HARDWOOD F14

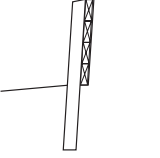
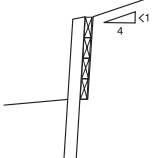
Backfill Angle	Wall Height (mm)	Section	Wale Length (mm)					
			900	1200	1500	1800	2100	2400
			Post Spacing (mm)					
			900	1200	1500	1800	2100	2400
Level 	1000	Posts Wales Footings	75dx200w 200dx50w 1400dx450	100dx200w 200dx50w 1400dx450	100dx200w 200dx50w 1500dx450	100dx200w 200dx75w 1600dx450	100dx200w 200dx75w 1600dx450	200dx75w 200dx100w 1700dx450
	1200	Posts Wales Footings	100dx200w 200dx50w 1500dx450	200dx75w 200dx50w 1600dx450	200dx75w 200dx75w 1700dx450	200dx75w 200dx75w 1700dx450	200dx75w 200dx75w 1800dx450	200dx100w 200dx100w 1900dx450
	1400	Posts Wales Footings	200dx75w 200dx50w 1700dx450	200dx75w 200dx50w 1800dx450	200dx75w 200dx75w 1900dx450	200dx100w 200dx75w 1900dx450	2/200dx75w 200dx100w 2000dx450	2/200dx75w 200dx100w 2100dx450
	1600	Posts Wales Footings	200dx100w 200dx50w 1900dx450	2/200dx75w 200dx50w 2000dx450	2/200dx75w 200dx75w 2200dx450	2/200dx100w 200dx75w 2300dx450	2/200dx100w 200dx100w 2400dx450	N/A 200dx100w 2500dx450
	1800	Posts Wales Footings	2/200dx75w 200dx50w 2100dx450	2/200dx75w 200dx75w 2200dx450	2/200dx100w 200dx75w 2400dx450	N/A 200dx100w 2500dx450	N/A 200dx100w 2700dx450	N/A N/A 2800dx450
	2000	Posts Wales Footings	2/200dx100w 200dx50w 2300dx450	N/A 200dx75w 2400dx450	N/A 200dx75w 2600dx450	N/A 200dx100w 2800dx450	N/A 200dx100w 2900dx450	N/A N/A 3100dx450
	2200	Posts Wales Footings	N/A 200dx50w 2400dx450	N/A 200dx75w 2700dx450	N/A 200dx75w 2900dx450	N/A 200dx100w 3100dx450	N/A 200dx100w 3200dx450	N/A N/A 3400dx450
	2400	Posts Wales Footings	N/A 200dx50w 2600dx450	N/A 200dx75w 2900dx450	N/A 200dx75w 3100dx450	N/A 200dx100w 3300dx450	N/A 200dx100w 3500dx450	N/A N/A 3700dx450
Less than 1 in 4 	1000	Posts Wales Footings	100dx200w 200dx50w 1400dx450	100dx200w 200dx50w 1500dx450	100dx200w 200dx75w 1600dx450	100dx200w 200dx75w 1600dx450	200dx75w 200dx75w 1700dx450	200dx75w 200dx100w 1700dx450
	1200	Posts Wales Footings	100dx200w 200dx50w 1600dx450	200dx75w 200dx50w 1600dx450	200dx75w 200dx75w 1700dx450	200dx75w 200dx75w 1800dx450	200dx100w 200dx100w 1900dx450	200dx100w 200dx100w 1900dx450
	1400	Posts Wales Footings	200dx75w 200dx50w 1700dx450	200dx75w 200dx50w 1800dx450	200dx100w 200dx75w 1900dx450	2/200dx75w 200dx75w 2000dx450	2/200dx75w 200dx100w 2100dx450	2/200dx75w 200dx100w 2200dx450
	1600	Posts Wales Footings	2/200dx75w 200dx50w 2000dx450	2/200dx75w 200dx75w 2100dx450	2/200dx100w 200dx75w 2300dx450	2/200dx100w 200dx100w 2400dx450	N/A 200dx100w 2500dx450	N/A N/A 2600dx450
	1800	Posts Wales Footings	2/200dx75w 200dx50w 2200dx450	2/200dx100w 200dx75w 2300dx450	N/A 200dx75w 2500dx450	N/A 200dx100w 2700dx450	N/A 200dx100w 2800dx450	N/A N/A 3000dx450
	2000	Posts Wales Footings	2/200dx100w 200dx50w 2400dx450	N/A 200dx75w 2600dx450	N/A 200dx75w 2800dx450	N/A 200dx100w 2900dx450	N/A 200dx100w 3100dx450	N/A N/A 3300dx450
	2200	Posts Wales Footings	N/A 200dx50w 2600dx450	N/A 200dx75w 2800dx450	N/A 200dx75w 3000dx450	N/A 200dx100w 3200dx450	N/A 200dx100w 3400dx450	N/A N/A 3600dx450
	2400	Posts Wales Footings	N/A 200dx50w 2800dx450	N/A 200dx75w 3000dx450	N/A 200dx75w 3300dx450	N/A 200dx100w 3500dx450	N/A N/A 3800dx450	N/A N/A 4000dx450

Notes:

a) Hardwood must be of In-ground Durability Class 1 with any sapwood preservative treated to H5 level

b) Hardwood must be graded to F14 in accordance with AS 2082

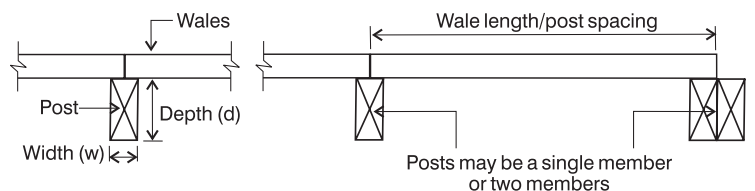
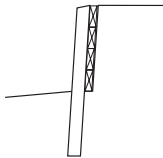
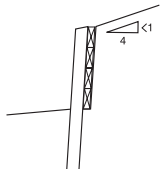

TABLE 2 - WALE ENDS CANTILEVERED BEYOND POSTS - SAWN HARDWOOD F14

Backfill Angle	Wall Height (mm)	Section	Wale Length (mm)					
			900	1200	1500	1800	2100	2400
			Post Spacing (mm) (A/B)					
			600/300	900/300	1100/400	1400/400	1650/450	1900/500
Level 	1000	Posts Wales Footings	75dx200w 200dx50w 1300dx450	75dx200w 200dx50w 1300dx450	75dx200w 200dx50w 1300dx450	75dx200w 200dx50w 1400dx450	100dx200w 200dx75w 1400dx450	100dx200w 200dx75w 1400dx450
	1200	Posts Wales Footings	75dx200w 200dx50w 1400dx450	100dx200w 200dx50w 1400dx450	100dx200w 200dx50w 1500dx450	100dx200w 200dx50w 1500dx450	100dx200w 200dx75w 1600dx450	200dx75w 200dx75w 1600dx450
	1400	Posts Wales Footings	100dx200w 200dx50w 1500dx450	200dx75w 200dx50w 1500dx450	200dx75w 200dx50w 1600dx450	200dx75w 200dx75w 1700dx450	200dx75w 200dx75w 1700dx450	200dx75w 200dx75w 1800dx450
	1600	Posts Wales Footings	200dx75w 200dx50w 1700dx450	200dx75w 200dx50w 1700dx450	200dx75w 200dx50w 1800dx450	200dx100w 200dx75w 1900dx450	2/200dx75w 200dx75w 2000dx450	2/200dx75w 200dx100w 2000dx450
	1800	Posts Wales Footings	200dx75w 200dx50w 1800dx450	200dx100w 200dx50w 1900dx450	2/200dx75w 200dx50w 2000dx450	2/200dx75w 200dx75w 2100dx450	2/200dx75w 200dx75w 2200dx450	2/200dx75w 200dx100w 2200dx450
	2000	Posts Wales Footings	200dx100w 200dx50w 1900dx450	2/200dx75w 200dx50w 2000dx450	2/200dx75w 200dx50w 2100dx450	2/200dx100w 200dx75w 2300dx450	2/200dx100w 200dx75w 2400dx450	N/A 200dx100w 2400dx450
	2200	Posts Wales Footings	2/200dx75w 200dx50w 2000dx450	2/200dx100w 200dx50w 2200dx450	2/200dx100w 200dx50w 2300dx450	N/A 200dx75w 2400dx450	N/A 200dx75w 2600dx450	N/A 200dx100w 2700dx450
	2400	Posts Wales Footings	2/200dx100w 200dx50w 2200dx450	N/A 200dx50w 2300dx450	N/A 200dx75w 2500dx450	N/A 200dx75w 2600dx450	N/A 200dx100w 2800dx450	N/A 200dx100w 2900dx450
Less than 1 in 4 	1000	Posts Wales Footings	75dx200w 200dx50w 1300dx450	75dx200w 200dx50w 1300dx450	75dx200w 200dx50w 1400dx450	100dx200w 200dx50w 1400dx450	100dx200w 200dx75w 1500dx450	100dx200w 200dx75w 1500dx450
	1200	Posts Wales Footings	100dx200w 200dx50w 1400dx450	100dx200w 200dx50w 1500dx450	100dx200w 200dx50w 1500dx450	100dx200w 200dx75w 1600dx450	200dx75w 200dx75w 1600dx450	200dx75w 200dx75w 1600dx450
	1400	Posts Wales Footings	100dx200w 200dx50w 1500dx450	200dx75w 200dx50w 1600dx450	200dx75w 200dx50w 1700dx450	200dx75w 200dx75w 1700dx450	200dx75w 200dx75w 1800dx450	200dx75w 200dx100w 1800dx450
	1600	Posts Wales Footings	200dx75w 200dx50w 1700dx450	200dx75w 200dx50w 1800dx450	200dx100w 200dx50w 1900dx450	2/200dx75w 200dx75w 2000dx450	2/200dx75w 200dx75w 2100dx450	2/200dx75w 200dx100w 2100dx450
	1800	Posts Wales Footings	200dx75w 200dx50w 1800dx450	200dx100w 200dx50w 2000dx450	2/200dx75w 200dx50w 2100dx450	2/200dx75w 200dx75w 2200dx450	2/200dx100w 200dx75w 2300dx450	2/200dx100w 200dx100w 2300dx450
	2000	Posts Wales Footings	2/200dx75w 200dx50w 2000dx450	2/200dx75w 200dx50w 2100dx450	2/200dx100w 200dx75w 2200dx450	2/200dx100w 200dx75w 2400dx450	N/A 200dx100w 2500dx450	N/A 200dx100w 2600dx450
	2200	Posts Wales Footings	2/200dx75w 200dx50w 2100dx450	2/200dx100w 200dx50w 2300dx450	N/A 200dx75w 2400dx450	N/A 200dx75w 2600dx450	N/A 200dx100w 2700dx450	N/A 200dx100w 2800dx450
	2400	Posts Wales Footings	2/200dx100w 200dx50w 2300dx450	N/A 200dx50w 2400dx450	N/A 200dx75w 2600dx450	N/A 200dx75w 2800dx450	N/A 200dx100w 2900dx450	N/A 200dx100w 3000dx450

Notes:

a) Hardwood must be of In-ground Durability Class 1 with any sapwood preservative treated to H5 level

b) Hardwood must be graded to F14 in accordance with AS 2082

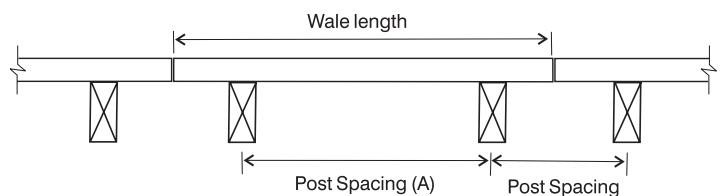
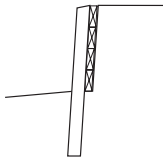
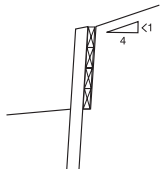

TABLE 3 - WALE JOINTS SUPPORTED AT POSTS - SAWN SOFTWOOD F7

Backfill Angle	Wall Height (mm)	Section	Wale Length (mm)							
			900	1200	1500	1800	2100	2400		
			Post Spacing (mm) (A/B)							
			900	1200	1500	1800	2100	2400		
Level 	1000	Posts Wales Footings	100dx200w 200dx50w 1400dx450	100dx200w 200dx50w 1400dx450	200dx75w 200dx75w 1500dx450	200dx75w 200dx75w 1600dx450	200dx100w 200dx100w 1600dx450	200dx100w 200dx100w 1700dx450		
	1200	Posts Wales Footings	200dx75w 200dx50w 1500dx450	200dx100w 200dx50w 1600dx450	200dx100w 200dx75w 1700dx450	2/200dx75w 200dx75w 1700dx450	2/200dx75w 200dx100w 1800dx450	2/200dx75w 200dx100w 1900dx450		
	1400	Posts Wales Footings	200dx100w 200dx50w 1700dx450	2/200dx75w 200dx75w 1800dx450	2/200dx75w 200dx75w 1900dx450	2/200dx100w 200dx100w 1900dx450	2/200dx100w 200dx100w 2000dx450	N/A N/A 2100dx450		
	1600	Posts Wales Footings	2/200dx100w 200dx50w 1900dx450	N/A 200dx75w 2000dx450	N/A 200dx75w 2200dx450	N/A 200dx100w 2300dx450	N/A 200dx100w 2400dx450	N/A N/A 2500dx450		
	1800	Posts Wales Footings	N/A 200dx50w 2100dx450	N/A 200dx75w 2200dx450	N/A 200dx75w 2400dx450	N/A 200dx100w 2500dx450	N/A N/A 2700dx450	N/A N/A 2800dx450		
	2000	Posts Wales Footings	N/A 200dx50w 2300dx450	N/A 200dx75w 2400dx450	N/A 200dx100w 2600dx450	N/A 200dx100w 2800dx450	N/A N/A 2900dx450	N/A N/A 3100dx450		
	2200	Posts Wales Footings	N/A 200dx50w 2400dx450	N/A 200dx75w 2700dx450	N/A 200dx100w 2900dx450	N/A 200dx100w 3100dx450	N/A N/A 3200dx450	N/A N/A 3400dx450		
	2400	Posts Wales Footings	N/A 200dx50w 2600dx450	N/A 200dx75w 2900dx450	N/A 200dx100w 3100dx450	N/A 200dx100w 3300dx450	N/A N/A 3500dx450	N/A N/A 3700dx450		
Less than 1 in 4 	1000	Posts Wales Footings	100dx200w 200dx50w 1400dx450	200dx75w 200dx50w 1500dx450	200dx75w 200dx75w 1600dx450	200dx100w 200dx75w 1600dx450	200dx100w 200dx100w 1700dx450	2/200dx75w 200dx100w 1700dx450		
	1200	Posts Wales Footings	200dx75w 200dx50w 1600dx450	200dx100w 200dx75w 1600dx450	2/200dx75w 200dx75w 1700dx450	2/200dx75w 200dx100w 1800dx450	2/200dx75w 200dx100w 1900dx450	2/200dx100w N/A 1900dx450		
	1400	Posts Wales Footings	2/200dx75w 200dx50w 1700dx450	2/200dx75w 200dx75w 1800dx450	2/200dx100w 200dx75w 1900dx450	2/200dx100w 200dx100w 2000dx450	N/A 200dx100w 2100dx450	N/A N/A 2200dx450		
	1600	Posts Wales Footings	2/200dx100w 200dx50w 2000dx450	N/A 200dx75w 2100dx450	N/A 200dx75w 2300dx450	N/A 200dx100w 2400dx450	N/A N/A 2500dx450	N/A N/A 2600dx450		
	1800	Posts Wales Footings	N/A 200dx50w 2200dx450	N/A 200dx75w 2300dx450	N/A 200dx100w 2500dx450	N/A 200dx100w 2700dx450	N/A N/A 2800dx450	N/A N/A 3000dx450		
	2000	Posts Wales Footings	N/A 200dx50w 2400dx450	N/A 200dx75w 2600dx450	N/A 200dx100w 2800dx450	N/A 200dx100w 2900dx450	N/A N/A 3100dx450	N/A N/A 3300dx450		
	2200	Posts Wales Footings	N/A 200dx50w 2600dx450	N/A 200dx75w 2800dx450	N/A 200dx100w 3000dx450	N/A 200dx100w 3200dx450	N/A N/A 3400dx450	N/A N/A 3600dx450		
	2400	Posts	N/A	N/A	N/A	N/A	N/A	N/A		

Notes:

- a) Softwood must be preservative treated to H5 level
- b) Softwood to be stress graded to not less than F7

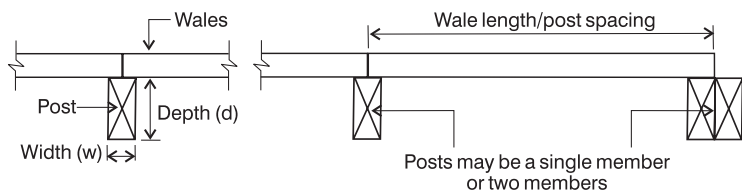
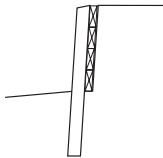
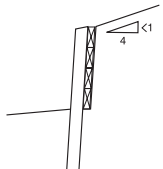

TABLE 4 - WALE ENDS CANTILEVERED BEYOND POSTS - SAWN SOFTWOOD F7

Backfill Angle	Wall Height (mm)	Section	Wale Length (mm)					
			900	1200	1500	1800	2100	2400
			Post Spacing (mm) (A/B)					
			600/300	900/300	1100/400	1400/400	1650/450	1900/500
Level 	1000	Posts Wales Footings	75dx200w 200dx50w 1300dx450	75dx200w 200dx50w 1300dx450	100dx200w 200dx50w 1300dx450	100dx200w 200dx75w 1400dx450	100dx200w 200dx75w 1400dx450	100dx200w 200dx75w 1400dx450
	1200	Posts Wales Footings	100dx200w 200dx50w 1400dx450	100dx200w 200dx50w 1400dx450	200dx75w 200dx50w 1500dx450	200dx75w 200dx75w 1500dx450	200dx75w 200dx75w 1600dx450	200dx100w 200dx100w 1600dx450
	1400	Posts Wales Footings	200dx75w 200dx50w 1500dx450	200dx75w 200dx50w 1500dx450	200dx75w 200dx50w 1600dx450	200dx100w 200dx75w 1700dx450	2/200dx75w 200dx75w 1700dx450	2/200dx75w 200dx100w 1800dx450
	1600	Posts Wales Footings	200dx100w 200dx50w 1700dx450	2/200dx75w 200dx50w 1700dx450	2/200dx75w 200dx75w 1800dx450	2/200dx100w 200dx75w 1900dx450	2/200dx100w 200dx100w 2000dx450	N/A 200dx100w 2000dx450
	1800	Posts Wales Footings	2/200dx75w 200dx50w 1800dx450	2/200dx75w 200dx50w 1900dx450	2/200dx100w 200dx75w 2000dx450	N/A 200dx75w 2100dx450	N/A 200dx100w 2200dx450	N/A 200dx100w 2200dx450
	2000	Posts Wales Footings	2/200dx100w 200dx50w 1900dx450	N/A 200dx50w 2000dx450	N/A 200dx75w 2100dx450	N/A 200dx75w 2300dx450	N/A 200dx100w 2400dx450	N/A 200dx100w 2400dx450
	2200	Posts Wales Footings	2/200dx100w 200dx50w 2000dx450	N/A 200dx50w 2200dx450	N/A 200dx75w 2300dx450	N/A 200dx75w 2400dx450	N/A 200dx100w 2600dx450	N/A 200dx100w 2700dx450
	2400	Posts Wales Footings	N/A 200dx50w 2200dx450	N/A 200dx50w 2300dx450	N/A 200dx75w 2500dx450	N/A 200dx100w 2600dx450	N/A 200dx100w 2800dx450	N/A N/A 2900dx450
Less than 1 in 4 	1000	Posts Wales Footings	75dx200w 200dx50w 1300dx450	100dx200w 200dx50w 1300dx450	100dx200w 200dx50w 1400dx450	100dx200w 200dx75w 1400dx450	100dx200w 200dx75w 1500dx450	200dx75w 200dx75w 1500dx450
	1200	Posts Wales Footings	100dx200w 200dx50w 1400dx450	100dx200w 200dx50w 1500dx450	200dx75w 200dx50w 1500dx450	200dx75w 200dx75w 1600dx450	200dx100w 200dx75w 1600dx450	200dx100w 200dx100w 1600dx450
	1400	Posts Wales Footings	200dx75w 200dx50w 1500dx450	200dx75w 200dx50w 1600dx450	200dx100w 200dx75w 1700dx450	2/200dx75w 200dx75w 1700dx450	2/200dx75w 200dx100w 1800dx450	2/200dx75w 200dx100w 1800dx450
	1600	Posts Wales Footings	2/200dx75w 200dx50w 1700dx450	2/200dx75w 200dx50w 1800dx450	2/200dx100w 200dx75w 1900dx450	2/200dx100w 200dx75w 2000dx450	N/A 200dx100w 2100dx450	N/A 200dx100w 2100dx450
	1800	Posts Wales Footings	2/200dx75w 200dx50w 1800dx450	2/200dx100w 200dx50w 2000dx450	N/A 200dx75w 2100dx450	N/A 200dx75w 2200dx450	N/A 200dx100w 2300dx450	N/A 200dx100w 2300dx450
	2000	Posts Wales Footings	2/200dx100w 200dx50w 2000dx450	N/A 200dx50w 2100dx450	N/A 200dx75w 2200dx450	N/A 200dx75w 2400dx450	N/A 200dx100w 2500dx450	N/A N/A 2600dx450
	2200	Posts Wales Footings	N/A 200dx50w 2100dx450	N/A 200dx50w 2300dx450	N/A 200dx75w 2400dx450	N/A 200dx100w 2600dx450	N/A 200dx100w 2700dx450	N/A N/A 2800dx450
	2400	Posts	N/A	N/A	N/A	N/A	N/A	N/A

Notes:

- a) Softwood must be preservative treated to H5 level
- b) Softwood to be stress graded to not less than F7

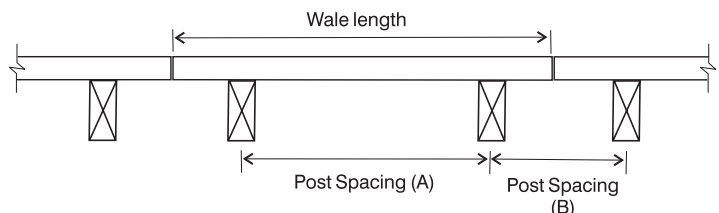
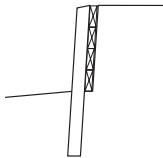
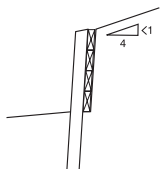

TABLE 5 - WALE JOINTS SUPPORTED AT POSTS - SOFTWOOD ROUNDS S6

Backfill Angle	Wall Height (mm)	Section	Wale Length (mm)					
			900	1200	1500	1800	2100	2400
			Post Spacing (mm)					
			900	1200	1500	1800	2100	2400
Level 	1000	Posts Wales Footings	125 dia 75 dia 1200dx300	150 dia 75 dia 1300dx300	150 dia 75 dia 1400dx300	175 dia 100 dia 1600dx450	175 dia 100 dia 1600dx450	175 dia 125 dia 1700dx450
	1200	Posts Wales Footings	150 dia 75 dia 1400dx300	175 dia 75 dia 1600dx450	175 dia 75 dia 1700dx450	200 dia 100 dia 1700dx450	200 dia 125 dia 1800dx450	225 dia 125 dia 1900dx450
	1400	Posts Wales Footings	175 dia 75 dia 1700dx450	200 dia 75 dia 1800dx450	225 dia 100 dia 1900dx450	225 dia 100 dia 1900dx450	225 dia 125 dia 2000dx450	250 dia 150 dia 2100dx450
	1600	Posts Wales Footings	225 dia 75 dia 1900dx450	250 dia 75 dia 2000dx450	300 dia 100 dia 2200dx450	300 dia 100 dia 2300dx450	300 dia 125 dia 2400dx450	300 dia 150 dia 2500dx450
	1800	Posts Wales Footings	250 dia 75 dia 2100dx450	300 dia 75 dia 2200dx450	300 dia 100 dia 2400dx450	N/A 125 dia 2500dx450	N/A 125 dia 2700dx450	N/A 150 dia 2800dx450
	2000	Posts Wales Footings	300 dia 75 dia 2300dx450	300 dia 75 dia 2400dx450	N/A 100 dia 2600dx450	N/A 125 dia 2800dx450	N/A 150 dia 2900dx450	N/A 150 dia 3100dx450
	2200	Posts Wales Footings	300 dia 75 dia 2400dx450	N/A 75 dia 2700dx450	N/A 100 dia 2900dx450	N/A 125 dia 3100dx450	N/A 150 dia 3200dx450	N/A 150 dia 3400dx450
	2400	Posts Wales Footings	N/A 75 dia 2600dx450	N/A 100 dia 2900dx450	N/A 100 dia 3100dx450	N/A 125 dia 3300dx450	N/A 150 dia 3500dx450	N/A 175 dia 3700dx450
Less than 1 in 4 	800	Posts Wales Footings	125 dia 75 dia 1100dx300	125 dia 75 dia 1200dx300	125 dia 75 dia 1200dx300	150 dia 100 dia 1300dx300	150 dia 100 dia 1300dx300	150 dia 125 dia 1400dx300
	1000	Posts Wales Footings	150 dia 75 dia 1200dx300	150 dia 75 dia 1300dx300	175 dia 75 dia 1600dx450	175 dia 100 dia 1600dx450	175 dia 125 dia 1700dx450	200 dia 125 dia 1700dx450
	1200	Posts Wales Footings	175 dia 75 dia 1600dx450	175 dia 75 dia 1600dx450	200 dia 100 dia 1700dx450	200 dia 100 dia 1800dx450	225 dia 125 dia 1900dx450	225 dia 125 dia 1900dx450
	1400	Posts Wales Footings	200 dia 75 dia 1700dx450	200 dia 75 dia 1800dx450	225 dia 100 dia 1900dx450	225 dia 100 dia 2000dx450	250 dia 125 dia 2100dx450	250 dia 150 dia 2200dx450
	1600	Posts Wales Footings	225 dia 75 dia 2000dx450	250 dia 75 dia 2100dx450	300 dia 100 dia 2300dx450	300 dia 125 dia 2400dx450	300 dia 125 dia 2500dx450	N/A 150 dia 2600dx450
	1800	Posts Wales Footings	300 dia 75 dia 2200dx450	300 dia 75 dia 2300dx450	300 dia 100 dia 2500dx450	N/A 125 dia 2700dx450	N/A 150 dia 2800dx450	N/A 150 dia 3000dx450
	2000	Posts Wales Footings	300 dia 75 dia 2400dx450	N/A 100 dia 2600dx450	N/A 100 dia 2800dx450	N/A 125 dia 2900dx450	N/A 150 dia 3100dx450	N/A 175 dia 3300dx450
	2200	Posts Wales Footings	N/A 75 dia 2600dx450	N/A 100 dia 2800dx450	N/A 125 dia 3000dx450	N/A 125 dia 3200dx450	N/A 150 dia 3400dx450	N/A N/A 3600dx450
	2400	Posts	N/A	N/A	N/A	N/A	N/A	N/A

Notes:

- a) Softwood rounds to be preservative treated to H5 level
- b) Softwood species shall be not less than strength group S6
- c) Where double posts are used, post sizes shall be determined by using 1/2 wale length / post spacing

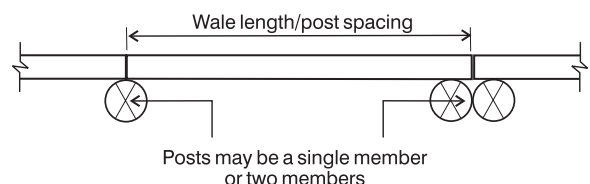
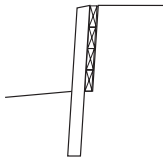
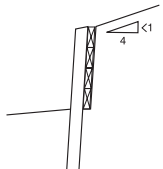

TABLE 6 - WALE ENDS CANTILEVERED BEYOND POSTS - SOFTWOOD ROUNDS S6

Backfill Angle	Wall Height (mm)	Section	Wale Length (mm)					
			900	1200	1500	1800	2100	2400
			Post Spacing (mm) (A/B)					
			600/300	900/300	1100/400	1400/400	1650/450	1900/500
Level 	1000	Posts Wales Footings	125 dia 75 dia 1100dx300	125 dia 75 dia 1100dx300	125 dia 75 dia 1200dx300	125 dia 75 dia 1200dx300	150 dia 100 dia 1200dx300	150 dia 100 dia 1300dx300
	1200	Posts Wales Footings	125 dia 75 dia 1200dx300	150 dia 75 dia 1300dx300	150 dia 75 dia 1300dx300	150 dia 75 dia 1400dx300	175 dia 100 dia 1600dx450	175 dia 100 dia 1600dx450
	1400	Posts Wales Footings	150 dia 75 dia 1300dx300	150 dia 75 dia 1400dx300	175 dia 75 dia 1600dx450	175 dia 75 dia 1700dx450	200 dia 100 dia 1700dx450	200 dia 100 dia 1800dx450
	1600	Posts Wales Footings	175 dia 75 dia 1700dx450	200 dia 75 dia 1700dx450	225 dia 75 dia 1800dx450	225 dia 100 dia 1900dx450	225 dia 100 dia 2000dx450	250 dia 125 dia 2000dx450
	1800	Posts Wales Footings	200 dia 75 dia 1800dx450	225 dia 75 dia 1900dx450	250 dia 75 dia 2000dx450	250 dia 100 dia 2100dx450	300 dia 100 dia 2200dx450	300 dia 125 dia 2200dx450
	2000	Posts Wales Footings	225 dia 75 dia 1900dx450	250 dia 75 dia 2000dx450	250 dia 75 dia 2100dx450	300 dia 100 dia 2300dx450	300 dia 100 dia 2400dx450	300 dia 125 dia 2400dx450
	2200	Posts Wales Footings	250 dia 75 dia 2000dx450	300 dia 75 dia 2200dx450	300 dia 75 dia 2300dx450	300 dia 100 dia 2400dx450	N/A 125 dia 2600dx450	N/A 125 dia 2700dx450
	2400	Posts Wales Footings	300 dia 75 dia 2200dx450	300 dia 75 dia 2300dx450	300 dia 75 dia 2500dx450	N/A 100 dia 2600dx450	N/A 125 dia 2800dx450	N/A 125 dia 2900dx450
Less than 1 in 4 	1000	Posts Wales Footings	125 dia 75 dia 1100dx300	125 dia 75 dia 1200dx300	125 dia 75 dia 1200dx300	150 dia 75 dia 1200dx300	150 dia 100 dia 1300dx300	150 dia 100 dia 1300dx300
	1200	Posts Wales Footings	125 dia 75 dia 1200dx300	150 dia 75 dia 1300dx300	150 dia 75 dia 1400dx300	175 dia 75 dia 1600dx450	175 dia 100 dia 1600dx450	175 dia 100 dia 1600dx450
	1400	Posts Wales Footings	150 dia 75 dia 1400dx300	175 dia 75 dia 1600dx450	175 dia 75 dia 1700dx450	200 dia 100 dia 1700dx450	200 dia 100 dia 1800dx450	200 dia 125 dia 1800dx450
	1600	Posts Wales Footings	200 dia 75 dia 1700dx450	200 dia 75 dia 1800dx450	225 dia 75 dia 1900dx450	225 dia 100 dia 2000dx450	250 dia 100 dia 2100dx450	250 dia 125 dia 2100dx450
	1800	Posts Wales Footings	200 dia 75 dia 1800dx450	225 dia 75 dia 2000dx450	250 dia 75 dia 2100dx450	300 dia 100 dia 2200dx450	300 dia 100 dia 2300dx450	300 dia 125 dia 2300dx450
	2000	Posts Wales Footings	225 dia 75 dia 2000dx450	250 dia 75 dia 2100dx450	300 dia 75 dia 2200dx450	300 dia 100 dia 2400dx450	300 dia 125 dia 2500dx450	N/A 125 dia 2600dx450
	2200	Posts Wales Footings	250 dia 75 dia 2100dx450	300 dia 75 dia 2300dx450	300 dia 75 dia 2400dx450	N/A 100 dia 2600dx450	N/A 125 dia 2700dx450	N/A 150 dia 2800dx450
	2400	Posts	300 dia	300 dia	N/A	N/A	N/A	N/A

Notes:

- a) Softwood rounds to be preservative treated to H5 level
- b) Softwood species shall be not less than strength group S6

