

Treated Pine provides a long lasting external cladding for buildings but attention must be paid to the correct storage, handling, fixing, finishing and maintenance of the product.

The most common types of treatment are waterborne (CCA, ACQ and copper azole) and LOSP (Light Organic Solvent Preservative). These preservatives protect the sapwood against decay and insect attack. Preservatives do not prevent weathering (i.e. where timber is exposed to sun and rain it turns silver/grey and may also become 'black' with surface mould with its surface becoming rough and possibly developing fine cracks).

Some treatments also contain water repellents. Where a water repellent has not been incorporated in the treatment process, it is recommended a water repellent preservative be applied on-site, particularly cut ends. The application of a water repellent preservative reduces the rate of moisture loss or uptake thereby reducing initial movement, distortion and surface checking.

PRODUCT SPECIFICATION

Preservative treated pine cladding should comply with Australian Standard AS 4785 or applicable industry standards.

Profile

A range of weatherboard, shiplap and chamferboard profile are currently available. Critical dimensions to ensure satisfactory longterm performance are detailed in Figure 1.

Moisture Content

At the time of fixing the moisture content of treated pine cladding should not exceed 15%. This is to avoid problems caused by timber movement and shrinkage, and ensure satisfactory application of paints and stains.

STORAGE AND HANDLING

Store packs well clear of the ground on level supports spaced no more than 600 mm apart. Protect from sun, rain and extreme heat, preferably by storing under cover with packs wrapped and sealed. This is to keep moisture out and prevent bowing and sagging. Pine cladding is relatively soft and requires care in handling to prevent damage. Keep clean and dry because marks and stains may not be hidden by clear or stain finishes.

FINISHING BEFORE FIXING

Clear or Exterior Pigmented Stain Finishes:

Priming - Where a water repellent has not been incorporated in the treatment process, cladding is to be given one coat all round of a water repellent preservative. No additional priming is required for water repellent treated cladding unless required by finish manufacturer for adhesion of finish coats.

First Coat of Stain - For all cladding where a pigmented stain finish is required, the first coat of stain is to be applied before fixing.

NOTE:

- (i) Solvent (oil) based stains are recommended
- (ii) The stain manufacturer's advice should be sought prior to applying the stain.
- (iii) A period of two weeks between the application of the water repellent preservative and the stain may be required.

Paint Finishes:

Priming - For all cladding where a painted finish is required, boards should be primed all round with a solvent (oil) based primer, plus one coat of undercoat colour matched to the final finishing coat. This will ensure that significant colour variations will not be apparent due to any shrinkage or movement that may occur later. Finish manufacturer's advice should be sought regarding compatibility of finish and water repellent treated cladding. Knots may be sealed with a 2 pack polyurethane or other sealer recommended by the paint manufacturer.

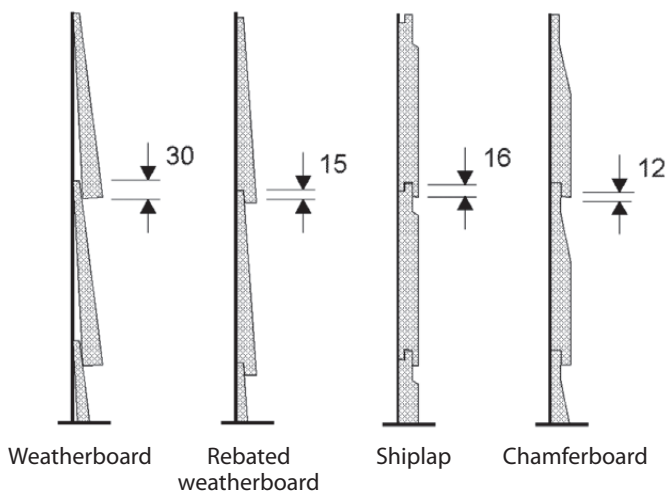

Figure 1. - Cladding Profiles

INSTALLATION

Sarking

Unless protected by a verandah roof, a reflective, waterproof, vapour permeable or breather type sarking should be installed behind all timber cladding to prevent penetration of water under severe rain and wind conditions. Sarking should be fixed on the outside of studs using disc type nails at 600 mm centres. Horizontal laps must not be less than 50 mm and vertical laps must be on studs.

NOTE:

The use of non-vapour permeable aluminium foil or plastic sarking directly behind timber cladding is not recommended as trapped vapour may cause cupping and distortion.

Joint Sealing

When a clear or stain finish has been chosen in conjunction with treated cladding, all freshly cut surfaces will require the application of a water repellent preservative. On all cladding to be painted, freshly cut ends are to be primed with the colour matched primer. All joints irrespective of the finish or type of treatment process used are to be sealed, including stopped ends, with a compatible mastic or silicone sealant. The sealant is to be placed onto the boards before fixing them into position.

Fixing

Where nailing guns are used, care should be taken to ensure that excess pressure does not distort the boards and that nails are not countersunk (heavy nailing distorts the wood and may cause splitting during weather changes). Wherever possible, cladding should be fastened so that the boards are free to shrink and swell individually. Cladding shall be fixed at not more than 650 mm centres measured along the board.

(i) Type of Nails

Suitable nails are:

- Hot dipped galvanised (not electro galvanised)
- Silicon Bronze
- Monel
- Stainless Steel

NOTE:

Flathead hot dipped galvanised nails are to be used with nailing guns.

(ii) For Weatherboards

One nail per board at each stud.

Drive nails as close as possible to the butt of the boards, but nails must not penetrate the tip or thinner edge of the board beneath, i.e. 30 mm lap, nail 35 mm from the butt (refer Figure 2).

Nail Size:

- For hardwood and cypress frames - 65 mm x 3.05 mm flat head nails.
- For softwood frames - 65 mm x 3.05 mm flat head (ring shank) nails.

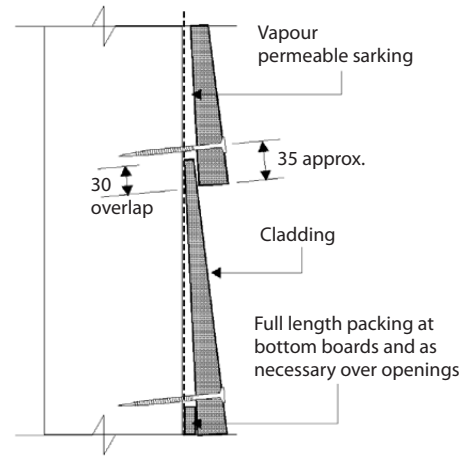

Figure 2. - Weatherboards

(iii) For Channel, Ship-Lap or Chamferboard Cladding

Two nails per board at each stud or nogging.

Nail Size:

- For hardwood and cypress frames - 60 mm x 2.8 mm flat head nails.
- For softwood frames - 60 mm x 3.05 flat head (ring shank) nails.

Nail to be driven approximately 25 mm from shoulder of boards (refer Figure 3).

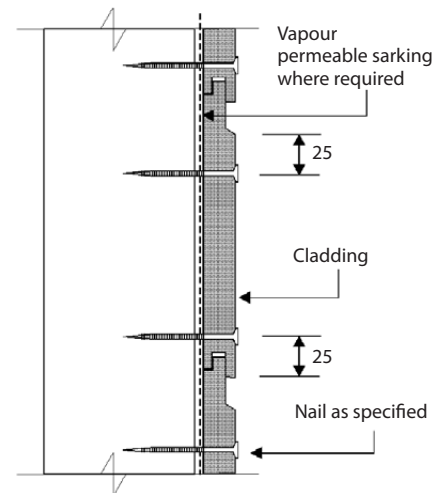

Figure 3. - Shiplap or Chamferboard

(iv) Diagonal Cladding of any Profile

Where cladding is fixed diagonally, the direction of fixing should not cause water to drain into internal corners or stops. Make adequate provision to discharge water clear of the building. With tongue and groove profiles, the tongue edge should always be up.

Flashing

Flash all openings in accordance with good building practice to prevent moisture penetration to the frame and the interior of the building.

FINISHING AFTER FIXING

For a clear finish to treated cladding not incorporating a water repellent, a final flood brushing with water repellent preservative is required.

NOTE:

Most 'clear' water repellent preservatives will darken the timber or may impart a light brown colour.

When an exterior pigmented stain or painted finish is chosen, one or two final coats should be applied in accordance with the manufacturer's recommendations. Light coloured paints and stains are recommended.

NOTE:

Where cladding is installed without the application of a surface coating, weathering and deterioration of these products will be accelerated.

MAINTENANCE

The long term performance of treated pine cladding is dependent on regular and effective maintenance. The frequency of maintenance will depend on the treatment process used, type of finish and the degree of exposure to the weather. For clear and stain finishes, recoating will be required after a period of approximately one to five years, whereas, a painted finish will require recoating after five to ten years.

The recoating and any further preparations are to be carried out in accordance with the finish manufacturer's specifications. Before recoating, the cladding should be cleaned and the joints resealed where required.

SAFE WORKING

Working with timber produces dust particles. Protection of the eyes, nose and mouth when sanding, sawing and planing is highly recommended. Refer to tool manufacturers for safe working recommendations for particular items of equipment.

DISPOSAL OF OFFCUTS AND WASTE

For any treated timber, do not burn offcuts or sawdust. Preservative treated offcuts and sawdust should be disposed of by approved local authority methods.



**TIMBER
QUEENSLAND**
We build Queensland

Timber Queensland Limited

ACN 092 686 756 | ABN 50 092 686 756

30 Boothby Street, Kedron
Brisbane Queensland 4031

Phone (07) 3358 7900

Fax (07) 3358 7999

PO Box 231, Kedron Qld 4031

admin@timberqueensland.com.au

www.timberqueensland.com.au

Whilst every effort is made to ensure the accuracy of advice given, Timber Queensland Limited cannot accept liability for loss or damage arising from the use of the information supplied.